

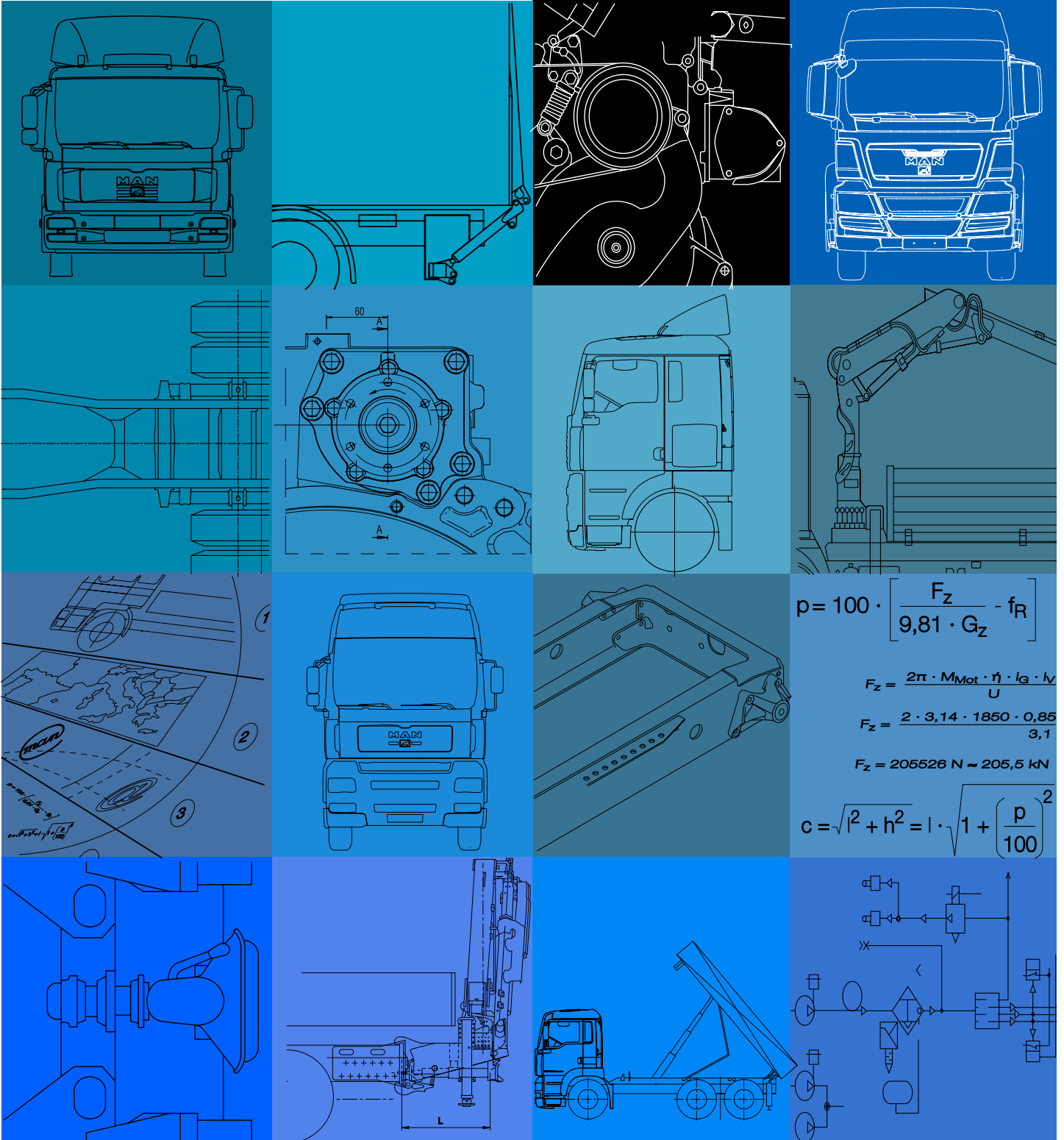

# Механизмы отбора мощности

## Технические данные и таблицы



## **Издатель**

**MAN Nutzfahrzeuge AG**

**Отдел TDB**

**Dachauer Str. 667**

**D - 80995 München**

**E-Mail:**

**tdb@de.man-mn.com**

**Факс:**

**+ 49 (0) 89 1580 4264**

MAN сохраняет за собой право внесения технических изменений, основанных на дальнейших конструкторских разработках.

© 2007 MAN Nutzfahrzeuge Aktiengesellschaft

Перепечатка, размножение или перевод данного руководства, в том числе его отдельных частей, без письменного согласия MAN Nutzfahrzeuge AG запрещены. Согласно закону об авторском праве все права принадлежат исключительно MAN.

Trucknology® и MANTED® являются зарегистрированными торговыми знаками MAN Nutzfahrzeuge AG

Права владельца торгового знака действительны, даже если наименование торгового знака не защищено символами (® ™).

1. Основные положения	1
2. Продолжительность работы и тип отбора мощности	1
3. Тип выходного вала механизма отбора мощности	1
4. Разрешенные моменты весовой нагрузки на механизм отбора мощности	2
5. Механизм отбора мощности от АКП ZF типа HP	2
6. Механизмы отбора мощности и интардер	2
7. Обзор механизмов отбора мощности	2
8. Технические данные и таблицы	3
Координаты x коробок передач и механизмов отбора мощности	3
Координаты y и z на чертежах коробок передач и механизмов отбора мощности	4
<b>AS-Lite</b>	9
6AS-850 6,72-0,79	
<b>AS-Mid</b>	
12AS-1210 TO 10,37-0,81	
<b>AS-Tronic</b>	
12AS1930 TD 15,86-1	
12AS2130 TD 15,86-1	
12AS2330 TD 15,86-1	
12AS1931 TD (c Intarder) 15,86-1	
12AS2131 TD (c Intarder) 15,86-1	
12AS2331 TD (c Intarder) 15,86-1	
12AS2330 TO 12,33-0,78	
12AS2530 TO 12,33-0,78	
12AS2331 TO (c Intarder) 12,33-0,78	
12AS2531 TO (c Intarder) 12,33-0,78	
12AS2740 TO 12,29-0,78	
12AS3140 TO 12,29-0,78	
12AS2741 TO (c Intarder) 12,29-0,78	
12AS3141 TO (c Intarder) 12,29-0,78	

**Ecolite**

S5-42 4,65-0,77

6S-850 6,72-0,79

6S-850 6,72-0,79

**Ecosplit**

16S-1820 TO 13,8-0,84

16S-1823 TO 13,8-0,84

16S-1821 TO (c Intarder) 13,8-0,84

16S-1822 TO (c NMV) 13,8-0,84

16S-1920 TD 16,41-1

16S-1923 TD 16,41-1

16S-2220 TD 16,41-1

16S-2223 TD 16,41-1

16S-2320 TD 16,41-1

16S-2323 TD 16,41-1

16S-1921 TD (c Intarder) 16,41-1

16S-2221 TD (c Intarder) 16,41-1

16S-2321 TD (c Intarder) 16,41-1

16S-2220 TO 13,8-0,84

16S-2223 TO 13,8-0,84

16S-2520 TO 13,8-0,84

16S-2520 TO 13,8-0,84

16S-2523 TO 13,8-0,84

16S-2221 TO (c Intarder) 13,8-0,84

16S-2521 TO (c Intarder) 13,8-0,84

16S-2222 TO (c NMV) 13,8-0,84

16S-2522 TO (c NMV) 13,8-0,84

**Ecomat**

6 HP 602 5,6-0,83

## 1. Основные положения

Необходимо отметить, что варианты механизмов отбора мощности, описанные в руководящих материалах по проведению кузовных работ, не всегда могут быть поставлены с завода. Информацию о серийно устанавливаемых механизмах отбора мощности можно найти в соответствующих дилерских документах MAN.

## 2. Продолжительность работы и тип отбора мощности

Механизмы отбора мощности можно классифицировать по:

- продолжительности работы;
- типу отбора мощности.

Продолжительность работы	Краткое обозначение в таблицах	Отбор мощности от двигателя со стороны маховика	Отбор мощности после сцепления
Кратковременное использование < 30 мин	K<30 мин		NS42/2
Кратковременное использование < 60 мин	K<60 мин		N../4b,c N36/5b,c NM AS/10b,c N109/10b,c
Длительное использование ≥ 60 мин.	D	NMV	N../1b,c N850/10b,c NAS/10b,c N221/10b,c с вентилятором или комплектом для охлаждения

## 3. Тип выходного вала механизма отбора мощности

Последняя позиция в обозначении механизма отбора мощности (буква «b» или «с») означает тип выходного вала механизма отбора мощности.

Нужно различать:

- Исполнение «b»: основное исполнение с фланцем для карданного привода;
- Исполнение «с»: для непосредственной установки насоса.

Исполнение «b» при некоторых обстоятельствах может быть получено из исполнения «с», Исполнение «с», в зависимости от варианта установки механизма привода, может быть преобразовано в исполнение «b».

#### 4. Разрешенные моменты весовой нагрузки на механизм отбора мощности

При непосредственном подключении насоса в исполнении «с» производитель работ должен учитывать, что весовой момент насоса со всеми навесными деталями (например, шлангами) не должен превышать допустимый уровень.

Разрешенный момент весовой нагрузки	Отбор мощности от коробки передач
	ZF
≤ 30 Нм	NL/1с, NL/4с, N36/5с, N850/10с, NS42/2с, N109/10с
≤ 50 Нм	NH/1с, NH/4с, N221/10с, NAS/10с, NM AS/10с

#### 5. Механизм отбора мощности от АКП ZF типа HP

На автоматические КП с гидротрансформатором типа ZF HP может быть установлено до 2 механизмов отбора мощности от двигателя. Направление вращения зависит от места установки (слева или справа от первичного вала КП).

Поэтому место установки указывается вместе с обозначением механизма отбора мощности, например, «D02с левый» — для установки слева от первичного вала. Внимание! Имеется в виду не направление вращения, а место установки на КП.

#### 6. Механизмы отбора мощности и интардер

Интардер ZF является вторичным тормозом-замедлителем (гидродинамическим тормозом), встроенным в корпус коробки передач.

Интардер может быть установлен на КП типа 12AS... и 16S и не мешает установке на коробку механизмов отбора мощности. Для установки некоторых механизмов при наличии интардера требуется адаптер или специальное исполнение для установки на КП с интардером. Такие механизмы обозначены в таблицах буквами «-IT», например, N221/10-IT.

#### 7. Обзор механизмов отбора мощности

В представленных ниже таблицах приведены характеристики различных механизмов отбора мощности, которые могут быть применены при наличии определенной коробки передач. Произвольное сочетание шасси — коробка передач — механизм отбора мощности возможно не всегда.

Информация о недопустимости некоторых из таких сочетаний может быть получена:

- из соответствующей документации или от дилера.

Действительным является только письменный ответ на письменный запрос.

Таблицы содержат технические данные механизмов отбора мощности в сочетании с определенной коробкой передач.

Эти данные включают:

- Направление вращения;
- Приведенное передаточное отношение (передаточное отношение приведенное к коленвалу двигателя). У коробок с делителем (позиция «L» или «I» для понижающих и «S» или «II» для повышающих передач) возможна реализация двух различных приведенных передаточных отношений;
- Разрешенный крутящий момент механизма отбора мощности при 1500 об/мин;
- Диаметр фланца;
- продолжительность работы (K < 30 мин, K < 60 мин, D);
- Место установки относительно промежуточного вала и первичного вала с указанием координат x, y и z.

## 8. Технические данные и таблицы

Координаты x коробок передач и механизмов отбора мощности

Механизм отбора мощности на задней части коробки передач

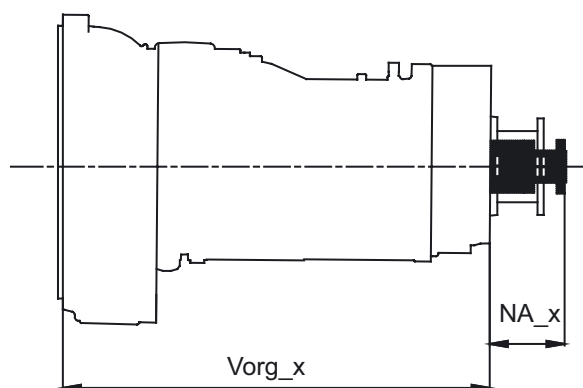

Механизм отбора мощности на N10

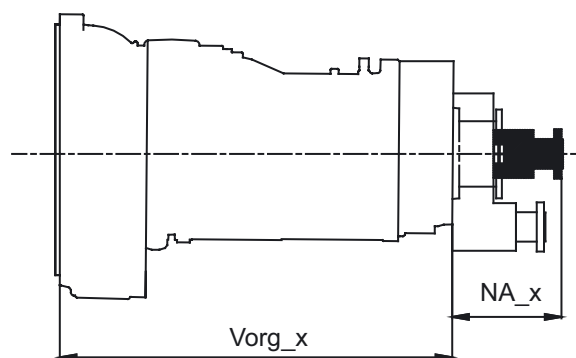

Механизм отбора мощности на коробке передач типа HP

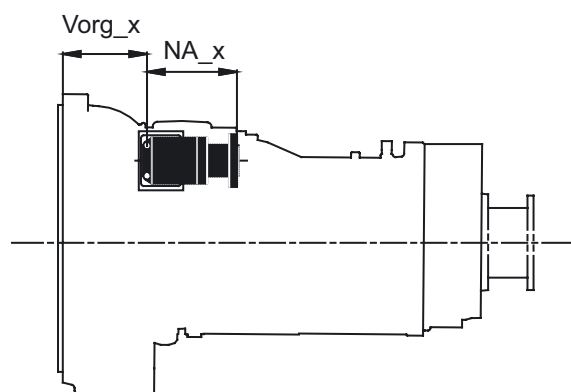

NMV

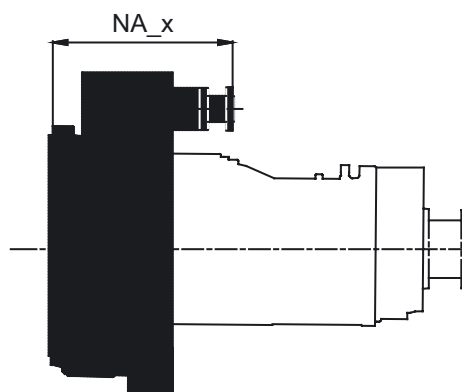

Vorg\_x: расстояние от фланца крепления КПП к двигателю до плоскости фланца для подсоединения механизма отбора мощности на коробке передач.

NA\_x: расстояние от фланца для подключения механизма отбора мощности на коробке передач до заднего края механизма (включая размер адаптера и фланца N10).

## Координаты у и z на чертежах коробок передач и механизмов отбора мощности

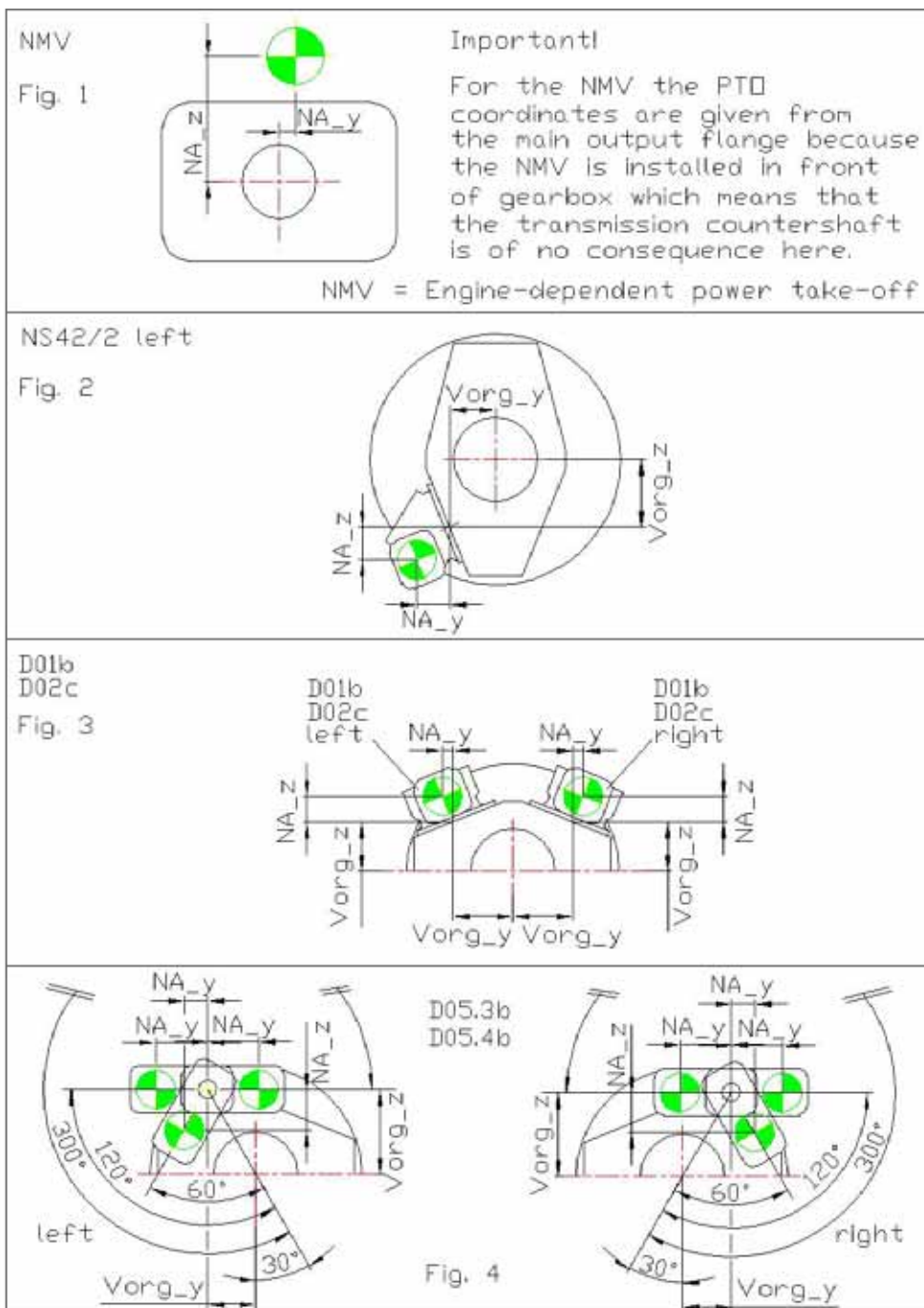

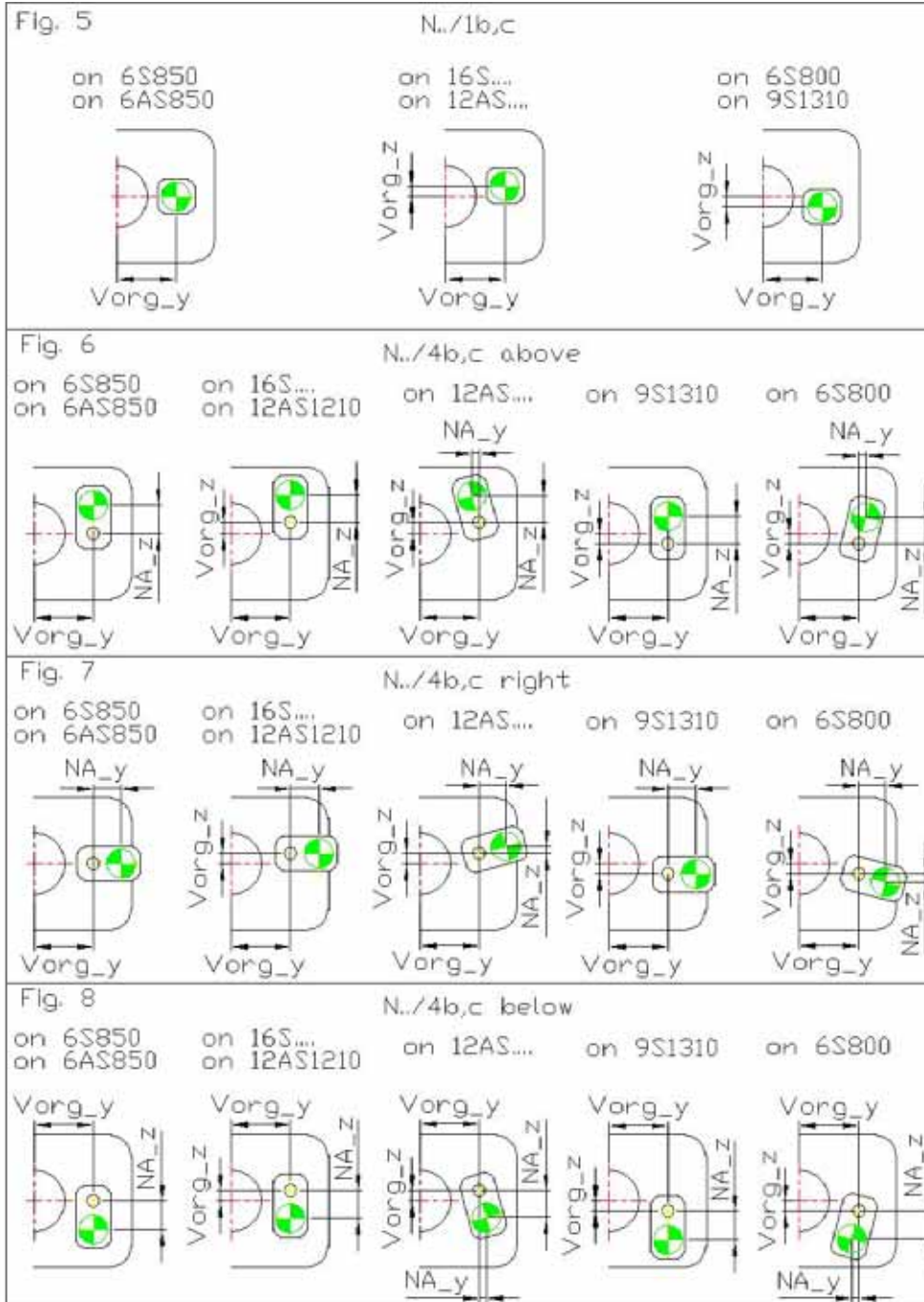

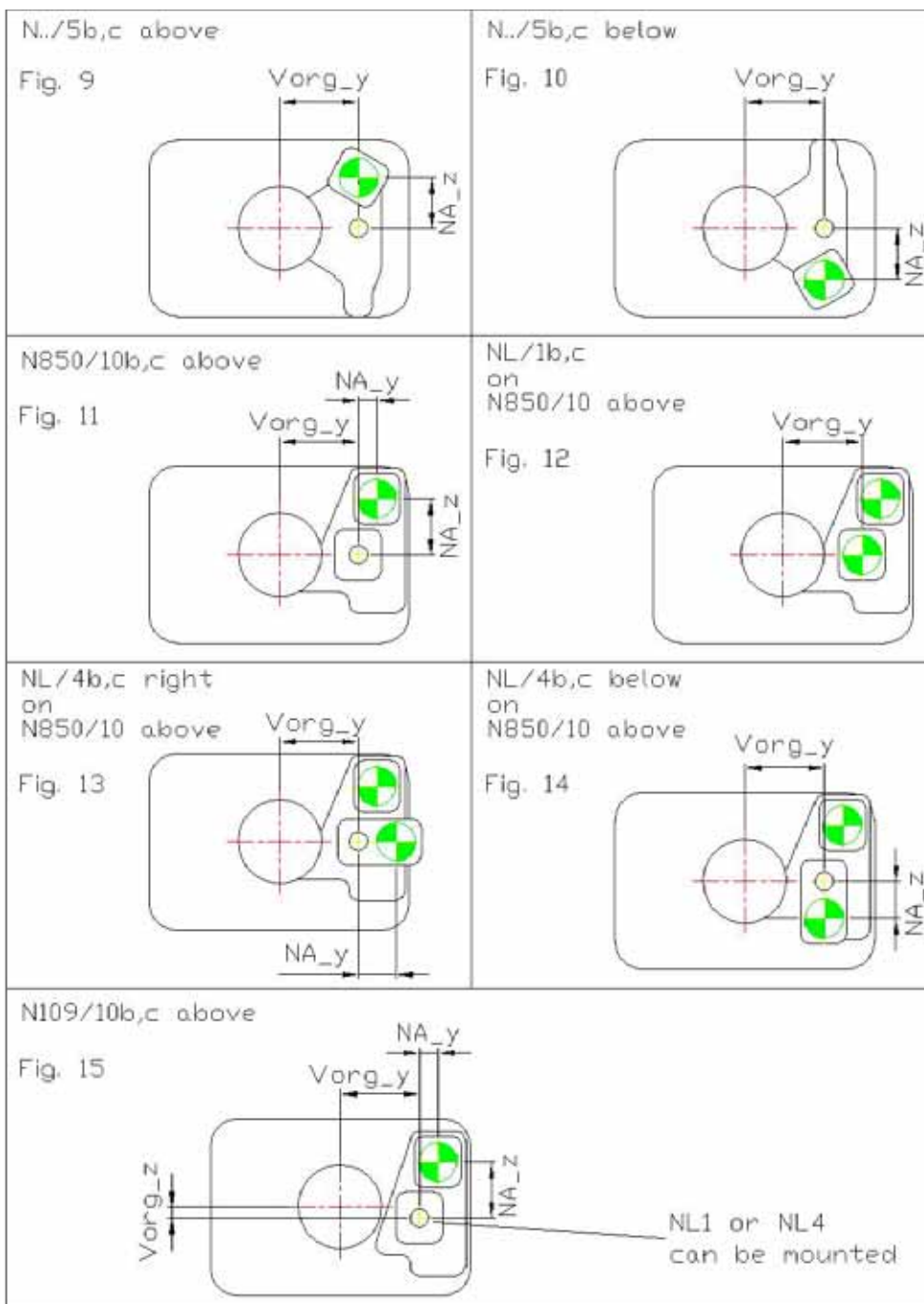

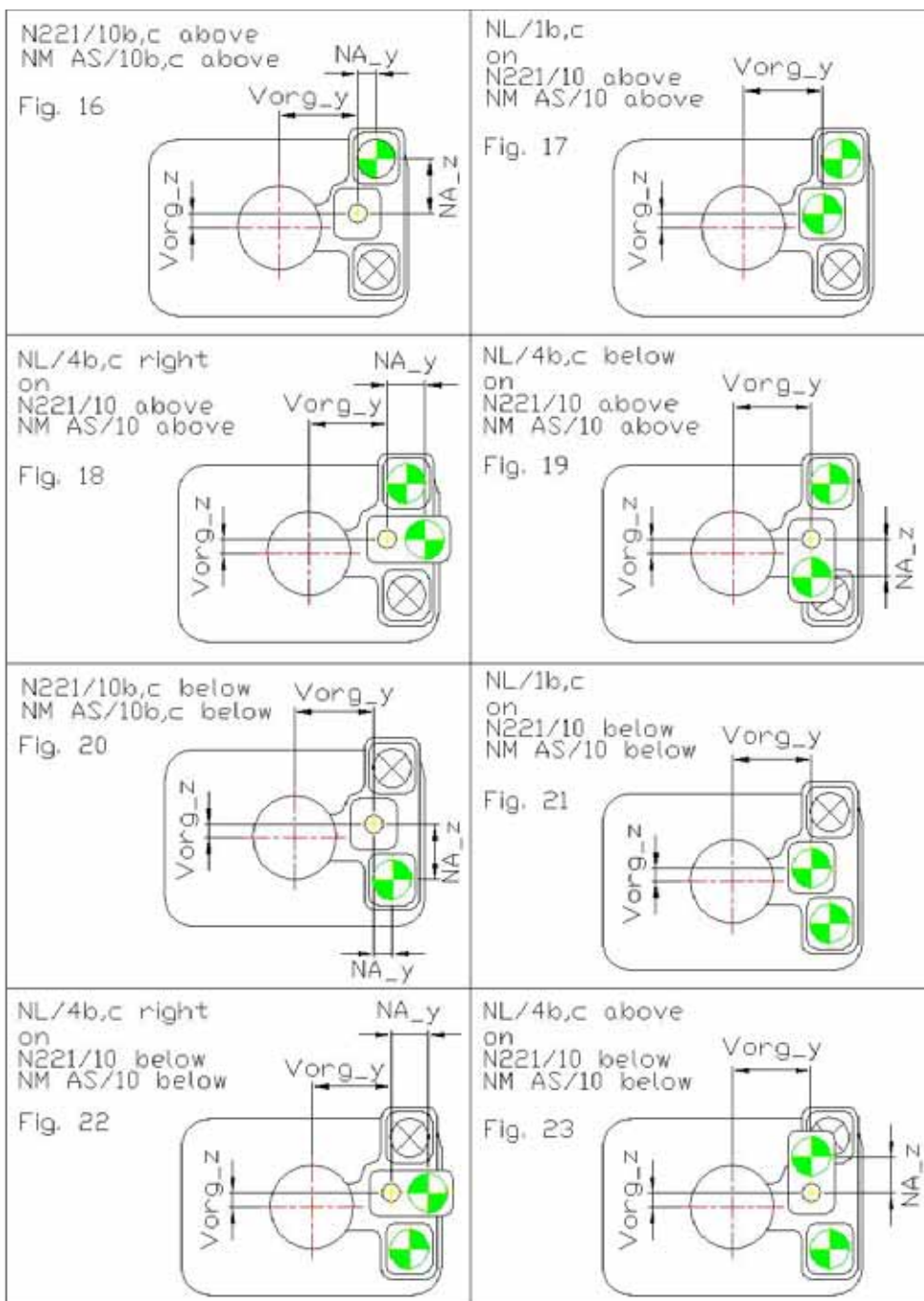

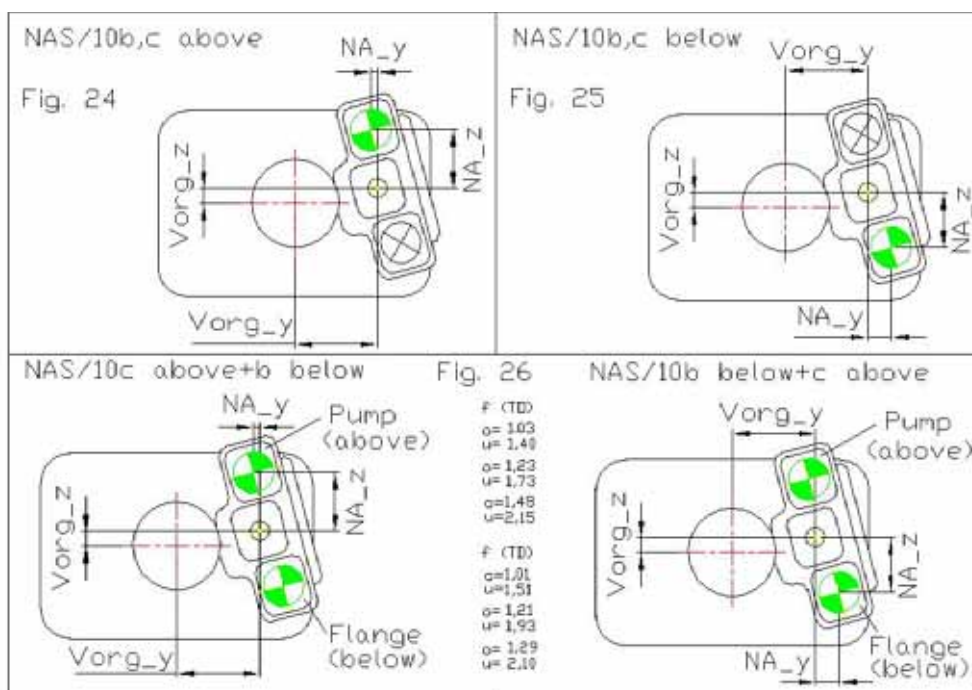

Vorg\_y: расстояние от оси выходного вала КПП до оси промежуточного вала КПП в поперечном направлении (+: вправо от выходного вала, -: влево).

NA\_y: расстояние от оси промежуточного вала КПП до оси выходного вала механизма отбора мощности в поперечном направлении (+: вправо от промежуточного вала, -: влево).

Vorg\_z: расстояние от оси выходного вала КПП до оси промежуточного вала КПП по вертикали (+: вверх от выходного вала, -: вниз).

NA\_z: расстояние от оси промежуточного вала КПП до оси выходного вала механизма отбора мощности по вертикали (+: вверх от промежуточного вала, -: вниз).

**AS-Lite**

Power take-offs for gearbox:							<b>6AS-850 (Standard) 6,72 – 0,79</b>			
Position: Gearbox output end right of main output flange										
Vorg_x [ mm ]: 622,00		Vorg_y [ mm ]: 120,00		Vorg_z [ mm ]: 0,00		Gearbox flange diameter [ mm ]: 120,00				
Designation	Direct. of rotation	Speed factor f	Torque [ Nm ]	Flange diameter [ mm ]	Operating period	Installed position	Fig. <span style="border: 1px solid black; padding: 0 2px;">a</span>	NA_x [ mm ]	NA_y [ mm ]	NA_z [ mm ]
N36/5b above	left	1,47	300	90,00	K<60 min	above	9	140,00	0,00	95,00
N36/5b above	left	1,11	400	90,00	K<60 min	above	9	140,00	0,00	95,00
N36/5b below	left	1,47	300	90,00	K<60 min	below	10	140,00	0,00	-95,00
N36/5b below	left	1,11	400	90,00	K<60 min	below	10	140,00	0,00	-95,00
N36/5c above	left	1,47	300		K<60 min	above	9	94,00	0,00	95,00
N36/5c above	left	1,11	400		K<60 min	above	9	94,00	0,00	95,00
N36/5c below	left	1,47	300		K<60 min	below	10	94,00	0,00	-95,00
N36/5c below	left	1,11	400		K<60 min	below	10	94,00	0,00	-95,00
NL/1b	right	0,53	600	90,00	D	coaxial	5	110,00	0,00	0,00
NL/1c	right	0,53	600		D	coaxial	5	52,00	0,00	0,00
NL/4b	left	0,68	430	90,00	K<60 min	above	6	142,00	0,00	80,00
NL/4b	left	0,68	430	90,00	K<60 min	right	7	142,00	80,00	0,00
NL/4b	left	0,68	430	90,00	K<60 min	below	8	142,00	0,00	-80,00
NL/4c	left	0,68	430		K<60 min	above	6	99,00	0,00	80,00
NL/4c	left	0,68	430		K<60 min	right	7	99,00	80,00	0,00
NL/4c	left	0,68	430		K<60 min	below	8	99,00	0,00	-80,00

Position: Gearbox output end right of main output flange										
Vorg_x [ mm ]: 622,00		Vorg_y [ mm ]: 120,00		Vorg_z [ mm ]: 0,00		Gearbox flange diameter [ mm ]: 150,00				
Designation	Direct. of rotation	Speed factor f	Torque [ Nm ]	Flange diameter [ mm ]	Operating period	Installed position	Fig. <span style="border: 1px solid black; padding: 0 2px;">a</span>	NA_x [ mm ]	NA_y [ mm ]	NA_z [ mm ]
N36/5b above	left	1,47	300	90,00	K<60 min	above	9	140,00	0,00	95,00
N36/5b above	left	1,11	400	90,00	K<60 min	above	9	140,00	0,00	95,00
N36/5b below	left	1,47	300	90,00	K<60 min	below	10	140,00	0,00	-95,00
N36/5b below	left	1,11	400	90,00	K<60 min	below	10	140,00	0,00	-95,00
N36/5c above	left	1,47	300		K<60 min	above	9	94,00	0,00	95,00
N36/5c above	left	1,11	400		K<60 min	above	9	94,00	0,00	95,00
N36/5c below	left	1,47	300		K<60 min	below	10	94,00	0,00	-95,00
N36/5c below	left	1,11	400		K<60 min	below	10	94,00	0,00	-95,00
NL/1b	right	0,53	600	90,00	D	coaxial	5	110,00	0,00	0,00
NL/1c	right	0,53	600		D	coaxial	5	52,00	0,00	0,00
NL/4b	left	0,68	430	90,00	K<60 min	above	6	142,00	0,00	80,00
NL/4b	left	0,68	430	90,00	K<60 min	right	7	142,00	80,00	0,00
NL/4b	left	0,68	430	90,00	K<60 min	below	8	142,00	0,00	-80,00
NL/4c	left	0,68	430		K<60 min	above	6	99,00	0,00	80,00
NL/4c	left	0,68	430		K<60 min	right	7	99,00	80,00	0,00
NL/4c	left	0,68	430		K<60 min	below	8	99,00	0,00	-80,00

**AS-Mid**

Power take-offs for gearbox:							12AS-1210 TO (Standard) 10,37 – 0,81					
Position: Gearbox output end right of main output flange												
Vorg_x [ mm ]: 739,00			Vorg_y [ mm ]: 210,00			Vorg_z [ mm ]: 20,00		Gearbox flange diameter [ mm ]: 155,00				
Designation	Direct. of rotation	Speed factor f *		Torque [ Nm ]	Flange diameter [ mm ]	Operating period	Installed position	Fig. <span style="border: 1px solid black; padding: 0 2px;">a</span>	NA_x [ mm ]	NA_y [ mm ]	NA_z [ mm ]	
		K2 <span style="border: 1px solid black; padding: 0 2px;">a</span>	K1									
NH/1b	right	0,99	1,22	800	90,00	D	coaxial	5	110,00	0,00	0,00	
NH/1c	right	0,99	1,22	800		D	coaxial	5	52,00	0,00	0,00	
NH/4b	left	0,89	1,10	430	90,00	K<60 min	above	6	142,00	0,00	80,00	
NH/4b	left	0,89	1,10	430	90,00	K<60 min	right	7	142,00	80,00	0,00	
NH/4b	left	0,89	1,10	430	90,00	K<60 min	below	8	142,00	0,00	-80,00	
NH/4c	left	0,89	1,10	430		K<60 min	above	6	99,00	0,00	80,00	
NH/4c	left	0,89	1,10	430		K<60 min	right	7	99,00	80,00	0,00	
NH/4c	left	0,89	1,10	430		K<60 min	below	8	99,00	0,00	-80,00	
NL/1b on NM AS/10 above	right	0,99	1,22	600	90,00	D	coaxial	17	264,00	0,00	0,00	
NL/1b on NM AS/10 below	right	0,99	1,22	600	90,00	D	coaxial	21	264,00	0,00	0,00	
NL/1c on NM AS/10 above	right	0,99	1,22	600		D	coaxial	17	206,00	0,00	0,00	
NL/1c on NM AS/10 below	right	0,99	1,22	600		D	coaxial	21	206,00	0,00	0,00	
NL/4b on NM AS/10 above	left	0,89	1,10	430	90,00	K<60 min	right	18	296,00	80,00	0,00	
NL/4b on NM AS/10 above	left	0,89	1,10	430	90,00	K<60 min	below	19	296,00	0,00	-80,00	
NL/4b on NM AS/10 below	left	0,89	1,10	430	90,00	K<60 min	above	23	296,00	0,00	80,00	
NL/4b on NM AS/10 below	left	0,89	1,10	430	90,00	K<60 min	right	22	296,00	80,00	0,00	
NL/4c on NM AS/10 above	left	0,89	1,10	430		K<60 min	right	18	253,00	80,00	0,00	
NL/4c on NM AS/10 above	left	0,89	1,10	430		K<60 min	below	19	253,00	0,00	-80,00	
NL/4c on NM AS/10 below	left	0,89	1,10	430		K<60 min	above	23	253,00	0,00	80,00	
NL/4c on NM AS/10 below	left	0,89	1,10	430		K<60 min	right	22	253,00	80,00	0,00	
NM AS/10b above	left	1,89	2,33	420	100,00	K<60 min#	above	16	176,00	8,00	113,00	
NM AS/10b above	left	1,47	1,80	510	100,00	K<60 min#	above	16	176,00	8,00	113,00	
NM AS/10b above	left	1,22	1,50	590	100,00	K<60 min#	above	16	176,00	8,00	113,00	
NM AS/10b below\$	left	1,89	2,33	420	100,00	K<60 min#	below	20	176,00	8,00	-113,00	
NM AS/10b below\$	left	1,47	1,80	510	100,00	K<60 min#	below	20	176,00	8,00	-113,00	
NM AS/10b below\$	left	1,22	1,50	590	100,00	K<60 min#	below	20	176,00	8,00	-113,00	
NM AS/10c above	left	1,89	2,33	420		K<60 min#	above	16	136,00	8,00	113,00	
NM AS/10c above	left	1,47	1,80	510		K<60 min#	above	16	136,00	8,00	113,00	
NM AS/10c above	left	1,22	1,50	590		K<60 min#	above	16	136,00	8,00	113,00	
NM AS/10c below\$	left	1,89	2,33	420		K<60 min#	below	20	136,00	8,00	-113,00	
NM AS/10c below\$	left	1,47	1,80	510		K<60 min#	below	20	136,00	8,00	-113,00	
NM AS/10c below\$	left	1,22	1,50	590		K<60 min#	below	20	136,00	8,00	-113,00	

\* The constant value "K1" is installed ex-works

# Continuous operation: with fan(for flange) or cooling set

\$ only with frame height 270mm a

## AS-Tronic

Power take-offs for gearbox:							12AS-1930 TD (Standard) 15,86 – 1			
							12AS-2130 TD (Standard) 15,86 – 1			
							12AS-2330 TD (Standard) 15,86 – 1			
Position: Gearbox output end right of main output flange										
Vorg_x [ mm ]: 800,50		Vorg_y [ mm ]: 140,10		Vorg_z [ mm ]: 37,50		Gearbox flange diameter [ mm ]: 180,00				
Designation	Direct. of rotation	Speed factor f	Torque [ Nm ]	Flange diameter [ mm ]	Operating period	Installed position	Fig. <span style="border: 1px solid red; padding: 0 2px;">a</span>	NA_x [ mm ]	NA_y [ mm ]	NA_z [ mm ]
NAS/10b above	left	1,93	400	100,00	D	above	24	254,00	-15,00	94,50
NAS/10b above <span style="border: 1px solid red; padding: 0 2px;">a</span>	left	1,52	430	100,00	D	above	24	254,00	-15,00	94,50
NAS/10b above <span style="border: 1px solid red; padding: 0 2px;">a</span>	left	1,29	630	100,00	D	above	24	254,00	-19,50	111,00
NAS/10b below	left	2,10	360	100,00	D	below	25	254,00	34,50	-90,00
NAS/10b below	left	1,93	400	100,00	D	below	25	254,00	34,50	-90,00
NAS/10b below(f=1,52) +c above(f=1,01)	left	1,52	430	100,00	D	below	26	254,00	34,50	-90,00
NAS/10b below(f=1,93) +c above(f=1,21)	left	1,93	400	100,00	D	below	26	254,00	34,50	-90,00
NAS/10b below(f=2,10) +c above(f=1,29)	left	2,10	360	100,00	D	below	26	254,00	34,50	-90,00
NAS/10c above	left	1,21	670		D	above	24	196,00	-19,50	111,00
NAS/10c above	left	1,01	690		D	above	24	196,00	-19,50	111,00
NAS/10c above(f=1,01) +b below(f=1,52)	left	1,01	690		D	above	26	196,00	-19,50	111,00
NAS/10c above(f=1,21) +b below(f=1,93)	left	1,21	670		D	above	26	196,00	-19,50	111,00
NAS/10c above(f=1,29) +b below(f=2,10)	left	1,29	630		D	above	26	196,00	-19,50	111,00
NAS/10c below	left	1,21	670		D	below	25	196,00	39,00	-107,00
NAS/10c below <span style="border: 1px solid red; padding: 0 2px;">a</span>	left	1,01	690		D	below	25	196,00	39,00	-107,00
NH/1b	right	0,82	1000	90,00	D	coaxial	5	110,00	0,00	0,00
NH/1c	right	0,82	1000		D	coaxial	5	52,00	0,00	0,00
NH/4b	left	1,05	430	90,00	K<60 min	above	6	142,00	-21,00	77,00
NH/4b	left	1,05	430	90,00	K<60 min	right	7	142,00	77,00	21,00
NH/4b	left	1,05	430	90,00	K<60 min	below	8	142,00	21,00	-77,00
NH/4c	left	1,05	430		K<60 min	above	6	99,00	-21,00	77,00
NH/4c	left	1,05	430		K<60 min	right	7	99,00	77,00	21,00
NH/4c	left	1,05	430		K<60 min	below	8	99,00	21,00	-77,00

Power take-offs for gearbox:							12AS-1931 TD (with Intarder) 15,86 – 1			
							12AS-2131 TD (with Intarder) 15,86 – 1			
							12AS-2331 TD (with Intarder) 15,86 – 1			
Position: Gearbox output end right of main output flange										
Vorg_x [ mm ]: 800,50		Vorg_y [ mm ]: 140,10		Vorg_z [ mm ]: 37,50		Gearbox flange diameter [ mm ]: 180,00				
Designation	Direct. of rotation	Speed factor f	Torque [ Nm ]	Flange diameter [ mm ]	Operating period	Installed position	Fig. <span style="border: 1px solid red; padding: 0 2px;">a</span>	NA_x [ mm ]	NA_y [ mm ]	NA_z [ mm ]
NAS/10b above	left	1,93	400	100,00	D	above	24	254,00	-15,00	94,50
NAS/10b above <span style="border: 1px solid red; padding: 0 2px;">a</span>	left	1,52	430	100,00	D	above	24	254,00	-15,00	94,50
NAS/10b above <span style="border: 1px solid red; padding: 0 2px;">a</span>	left	1,29	630	100,00	D	above	24	254,00	-19,50	111,00
NAS/10b below	left	2,10	360	100,00	D	below	25	254,00	34,50	-90,00
NAS/10b below	left	1,93	400	100,00	D	below	25	254,00	34,50	-90,00
NAS/10b below(f=1,52) +c above(f=1,01)	left	1,52	430	100,00	D	below	26	254,00	34,50	-90,00
NAS/10b below(f=1,93) +c above(f=1,21)	left	1,93	400	100,00	D	below	26	254,00	34,50	-90,00
NAS/10b below(f=2,10) +c above(f=1,29)	left	2,10	360	100,00	D	below	26	254,00	34,50	-90,00
NAS/10c above	left	1,21	670		D	above	24	196,00	-19,50	111,00
NAS/10c above	left	1,01	690		D	above	24	196,00	-19,50	111,00
NAS/10c above(f=1,01) +b below(f=1,52)	left	1,01	690		D	above	26	196,00	-19,50	111,00
NAS/10c above(f=1,21) +b below(f=1,93)	left	1,21	670		D	above	26	196,00	-19,50	111,00
NAS/10c above(f=1,29) +b below(f=2,10)	left	1,29	630		D	above	26	196,00	-19,50	111,00
NAS/10c below	left	1,21	670		D	below	25	196,00	39,00	-107,00
NAS/10c below <span style="border: 1px solid red; padding: 0 2px;">a</span>	left	1,01	690		D	below	25	196,00	39,00	-107,00
NH/1b(AS)-IT	right	0,82	1000	90,00	D	coaxial	5	133,50	0,00	0,00
NH/1c(AS)-IT	right	0,82	1000		D	coaxial	5	75,50	0,00	0,00
NH/4b(AS)-IT	left	1,05	430	90,00	K<60 min	above	6	165,50	-21,00	77,00
NH/4b(AS)-IT	left	1,05	430	90,00	K<60 min	right	7	165,50	77,00	21,00
NH/4b(AS)-IT	left	1,05	430	90,00	K<60 min	below	8	165,50	21,00	-77,00
NH/4c(AS)-IT	left	1,05	430		K<60 min	above	6	122,50	-21,00	77,00
NH/4c(AS)-IT	left	1,05	430		K<60 min	right	7	122,50	77,00	21,00
NH/4c(AS)-IT	left	1,05	430		K<60 min	below	8	122,50	21,00	-77,00

Power take-offs for gearbox:							12AS-2330 TO (Standard) 12,33 – 0,78 12AS-2530 TO (Standard) 12,33 – 0,78			
Position: Gearbox output end right of main output flange										
Vorg_x [ mm ]: 800,50		Vorg_y [ mm ]: 140,10		Vorg_z [ mm ]: 37,50		Gearbox flange diameter [ mm ]: 180,00				
Designation	Direct. of rotation	Speed factor f	Torque [ Nm ]	Flange diameter [ mm ]	Operating period	Installed position	Fig. <span style="border: 1px solid red; padding: 0 2px;">a</span>	NA_x [ mm ]	NA_y [ mm ]	NA_z [ mm ]
NAS/10b above	left	2,15	490	100,00	D	above	24	254,00	-15,00	94,50
NAS/10b above	left	1,73	580	100,00	D	above	24	254,00	-15,00	94,50
NAS/10b above	left	1,47	710	100,00	D	above	24	254,00	-19,50	111,00
NAS/10b below	left	2,15	490	100,00	D	below	25	254,00	34,50	-90,00
NAS/10b below	left	1,73	580	100,00	D	below	25	254,00	34,50	-90,00
NAS/10b below	left	1,47	710	100,00	D	below	25	254,00	39,00	-107,00
NAS/10b below(f=1,39) +c above(f=1,03)	left	1,39	600	100,00	D	below	26	254,00	34,50	-90,00
NAS/10b below(f=1,73) +c above(f=1,23)	left	1,73	580	100,00	D	below	26	254,00	34,50	-90,00
NAS/10b below(f=2,15) +c above(f=1,47)	left	2,15	490	100,00	D	below	26	254,00	34,50	-90,00
NAS/10c above	left	1,23	720		D	above	24	196,00	-19,50	111,00
NAS/10c above	left	1,03	730		D	above	24	196,00	-19,50	111,00
NAS/10c above(f=1,03) +b below(f=1,39)	left	1,03	730		D	above	26	196,00	-19,50	111,00
NAS/10c above(f=1,23) +b below(f=1,73)	left	1,23	720		D	above	26	196,00	-19,50	111,00
NAS/10c above(f=1,47) +b below(f=2,15)	left	1,47	710		D	above	26	196,00	-19,50	111,00
NAS/10c below	left	1,23	720		D	below	25	196,00	39,00	-107,00
NAS/10c below	left	1,03	730		D	below	25	196,00	39,00	-107,00
NH/1b	right	1,35	1000	90,00	D	coaxial	5	110,00	0,00	0,00
NH/1c	right	1,35	1000		D	coaxial	5	52,00	0,00	0,00
NH/4b	left	1,22	430	90,00	K<60 min	above	6	142,00	-21,00	77,00
NH/4b	left	1,22	430	90,00	K<60 min	right	7	142,00	77,00	21,00
NH/4b	left	1,22	430	90,00	K<60 min	below	8	142,00	21,00	-77,00
NH/4c	left	1,22	430		K<60 min	above	6	99,00	-21,00	77,00
NH/4c	left	1,22	430		K<60 min	right	7	99,00	77,00	21,00
NH/4c	left	1,22	430		K<60 min	below	8	99,00	21,00	-77,00

Power take-offs for gearbox:							12AS-2331 TO (with Intarder) 12,33 – 0,78 12AS-2531 TO (with Intarder) 12,33 – 0,78			
Position: Gearbox output end right of main output flange										
Vorg_x [ mm ]: 800,50		Vorg_y [ mm ]: 140,10		Vorg_z [ mm ]: 37,50		Gearbox flange diameter [ mm ]: 180,00				
Designation	Direct. of rotation	Speed factor f	Torque [ Nm ]	Flange diameter [ mm ]	Operating period	Installed position	Fig. <span style="border: 1px solid black; padding: 0 2px;">a</span>	NA_x [ mm ]	NA_y [ mm ]	NA_z [ mm ]
NAS/10b above	left	2,15	490	100,00	D	above	24	254,00	-15,00	94,50
NAS/10b above	left	1,73	580	100,00	D	above	24	254,00	-15,00	94,50
NAS/10b above	left	1,47	710	100,00	D	above	24	254,00	-19,50	111,00
NAS/10b below	left	2,15	490	100,00	D	below	25	254,00	34,50	-90,00
NAS/10b below	left	1,73	580	100,00	D	below	25	254,00	34,50	-90,00
NAS/10b below	left	1,47	710	100,00	D	below	25	254,00	39,00	-107,00
NAS/10b below(f=1,39) +c above(f=1,03)	left	1,39	600	100,00	D	below	26	254,00	34,50	-90,00
NAS/10b below(f=1,73) +c above(f=1,23)	left	1,73	580	100,00	D	below	26	254,00	34,50	-90,00
NAS/10b below(f=2,15) +c above(f=1,47)	left	2,15	490	100,00	D	below	26	254,00	34,50	-90,00
NAS/10c above	left	1,23	720		D	above	24	196,00	-19,50	111,00
NAS/10c above	left	1,03	730		D	above	24	196,00	-19,50	111,00
NAS/10c above(f=1,03) +b below(f=1,39)	left	1,03	730		D	above	26	196,00	-19,50	111,00
NAS/10c above(f=1,23) +b below(f=1,73)	left	1,23	720		D	above	26	196,00	-19,50	111,00
NAS/10c above(f=1,47) +b below(f=2,15)	left	1,47	710		D	above	26	196,00	-19,50	111,00
NAS/10c below	left	1,23	720		D	below	25	196,00	39,00	-107,00
NAS/10c below	left	1,03	730		D	below	25	196,00	39,00	-107,00
NH/1b(AS)-IT	right	1,35	1000	90,00	D	coaxial	5	133,50	0,00	0,00
NH/1c(AS)-IT	right	1,35	1000		D	coaxial	5	75,50	0,00	0,00
NH/4b(AS)-IT	left	1,22	430	90,00	K<60 min	above	6	165,50	-21,00	77,00
NH/4b(AS)-IT	left	1,22	430	90,00	K<60 min	right	7	165,50	77,00	21,00
NH/4b(AS)-IT	left	1,22	430	90,00	K<60 min	below	8	165,50	21,00	-77,00
NH/4c(AS)-IT	left	1,22	430		K<60 min	above	6	122,50	-21,00	77,00
NH/4c(AS)-IT	left	1,22	430		K<60 min	right	7	122,50	77,00	21,00
NH/4c(AS)-IT	left	1,22	430		K<60 min	below	8	122,50	21,00	-77,00

Power take-offs for gearbox:							12AS-2740 TO (Standard) 12,29 – 0,78 12AS-3140 TO (Standard) 12,29 – 0,78			
Position: Gearbox output end right of main output flange										
Vorg_x [ mm ]: 843,50		Vorg_y [ mm ]: 140,10		Vorg_z [ mm ]: 37,50		Gearbox flange diameter [ mm ]: 180,00				
Designation	Direct. of rotation	Speed factor f	Torque [ Nm ]	Flange diameter [ mm ]	Operating period	Installed position	Fig. <span style="border: 1px solid red; padding: 0 2px;">a</span>	NA_x [ mm ]	NA_y [ mm ]	NA_z [ mm ]
NAS/10b above	left	2,15	490	100,00	D	above	24	254,00	-15,00	94,50
NAS/10b above	left	1,73	580	100,00	D	above	24	254,00	-15,00	94,50
NAS/10b above	left	1,47	710	100,00	D	above	24	254,00	-19,50	111,00
NAS/10b below	left	2,15	490	100,00	D	below	25	254,00	34,50	-90,00
NAS/10b below	left	1,73	580	100,00	D	below	25	254,00	34,50	-90,00
NAS/10b below	left	1,47	710	100,00	D	below	25	254,00	39,00	-107,00
NAS/10b below(f=1,39) +c above(f=1,03)	left	1,39	600	100,00	D	below	26	254,00	34,50	-90,00
NAS/10b below(f=1,73) +c above(f=1,23)	left	1,73	580	100,00	D	below	26	254,00	34,50	-90,00
NAS/10b below(f=2,15) +c above(f=1,47)	left	2,15	490	100,00	D	below	26	254,00	34,50	-90,00
NAS/10c above	left	1,23	720		D	above	24	196,00	-19,50	111,00
NAS/10c above	left	1,03	730		D	above	24	196,00	-19,50	111,00
NAS/10c above(f=1,03) +b below(f=1,39)	left	1,03	730		D	above	26	196,00	-19,50	111,00
NAS/10c above(f=1,23) +b below(f=1,73)	left	1,23	720		D	above	26	196,00	-19,50	111,00
NAS/10c above(f=1,47) +b below(f=2,15)	left	1,47	710		D	above	26	196,00	-19,50	111,00
NAS/10c below	left	1,23	720		D	below	25	196,00	39,00	-107,00
NAS/10c below	left	1,03	730		D	below	25	196,00	39,00	-107,00
NH/1b	right	1,35	1000	90,00	D	coaxial	5	110,00	0,00	0,00
NH/1c	right	1,35	1000		D	coaxial	5	52,00	0,00	0,00
NH/4b	left	1,22	430	90,00	K<60 min	above	6	142,00	-21,00	77,00
NH/4b	left	1,22	430	90,00	K<60 min	right	7	142,00	77,00	21,00
NH/4b	left	1,22	430	90,00	K<60 min	below	8	142,00	21,00	-77,00
NH/4c	left	1,22	430		K<60 min	above	6	99,00	-21,00	77,00
NH/4c	left	1,22	430		K<60 min	right	7	99,00	77,00	21,00
NH/4c	left	1,22	430		K<60 min	below	8	99,00	21,00	-77,00

Power take-offs for gearbox:							12AS-2741 TO (with Intarder) 12,29 – 0,78 12AS-3141 TO (with Intarder) 12,29 – 0,78			
Position: Gearbox output end right of main output flange										
Vorg_x [ mm ]: 843,50		Vorg_y [ mm ]: 140,10		Vorg_z [ mm ]: 37,50		Gearbox flange diameter [ mm ]: 180,00				
Designation	Direct. of rotation	Speed factor f	Torque [ Nm ]	Flange diameter [ mm ]	Operating period	Installed position	Fig. <span style="border: 1px solid red; padding: 0 2px;">a</span>	NA_x [ mm ]	NA_y [ mm ]	NA_z [ mm ]
NAS/10b above	left	2,15	490	100,00	D	above	24	254,00	-15,00	94,50
NAS/10b above	left	1,73	580	100,00	D	above	24	254,00	-15,00	94,50
NAS/10b above	left	1,47	710	100,00	D	above	24	254,00	-19,50	111,00
NAS/10b below	left	2,15	490	100,00	D	below	25	254,00	34,50	-90,00
NAS/10b below	left	1,73	580	100,00	D	below	25	254,00	34,50	-90,00
NAS/10b below	left	1,47	710	100,00	D	below	25	254,00	39,00	-107,00
NAS/10b below(f=1,39) +c above(f=1,03)	left	1,39	600	100,00	D	below	26	254,00	34,50	-90,00
NAS/10b below(f=1,73) +c above(f=1,23)	left	1,73	580	100,00	D	below	26	254,00	34,50	-90,00
NAS/10b below(f=2,15) +c above(f=1,47)	left	2,15	490	100,00	D	below	26	254,00	34,50	-90,00
NAS/10c above	left	1,23	720		D	above	24	196,00	-19,50	111,00
NAS/10c above	left	1,03	730		D	above	24	196,00	-19,50	111,00
NAS/10c above(f=1,03) +b below(f=1,39)	left	1,03	730		D	above	26	196,00	-19,50	111,00
NAS/10c above(f=1,23) +b below(f=1,73)	left	1,23	720		D	above	26	196,00	-19,50	111,00
NAS/10c above(f=1,47) +b below(f=2,15)	left	1,47	710		D	above	26	196,00	-19,50	111,00
NAS/10c below	left	1,23	720		D	below	25	196,00	39,00	-107,00
NAS/10c below	left	1,03	730		D	below	25	196,00	39,00	-107,00
NH/1b(AS)-IT	right	1,35	1000	90,00	D	coaxial	5	133,50	0,00	0,00
NH/1c(AS)-IT	right	1,35	1000		D	coaxial	5	75,50	0,00	0,00
NH/4b(AS)-IT	left	1,22	430	90,00	K<60 min	above	6	165,50	-21,00	77,00
NH/4b(AS)-IT	left	1,22	430	90,00	K<60 min	right	7	165,50	77,00	21,00
NH/4b(AS)-IT	left	1,22	430	90,00	K<60 min	below	8	165,50	21,00	-77,00
NH/4c(AS)-IT	left	1,22	430		K<60 min	above	6	122,50	-21,00	77,00
NH/4c(AS)-IT	left	1,22	430		K<60 min	right	7	122,50	77,00	21,00
NH/4c(AS)-IT	left	1,22	430		K<60 min	below	8	122,50	21,00	-77,00

**Ecolite**

Power take-offs for gearbox:							<b>S5-42 (Standard) 4,65 – 0,77</b>			
Position: On the side of gearbox left of main output flange										
Vorg_x [ mm ]: 230,50		Vorg_y [ mm ]: -89,00		Vorg_z [ mm ]: 141,00		Gearbox flange diameter [ mm ]: 120,00				
Designation	Direct. of rotation	Speed factor f	Torque [ Nm ]	Flange diameter [ mm ]	Operating period	Installed position	Fig. <span style="border: 1px solid red; padding: 0 2px;">a</span>	NA_x [ mm ]	NA_y [ mm ]	NA_z [ mm ]
NS42/2b left	right	1,57	190	90,00	K<30 min	left	2	133,00	-71,00	-69,00
NS42/2b left	right	0,95	270	90,00	K<30 min	left	2	133,00	-71,00	-69,00
NS42/2c left	right	1,57	190		K<30 min	left	2	120,00	-71,00	-69,00
NS42/2c left	right	0,95	270		K<30 min	left	2	120,00	-71,00	-69,00

Power take-offs for gearbox:							<span style="border: 1px solid red; padding: 0 2px;">a</span> 6S-800 TO (Standard) 6,58 – 0,78			
Position: Gearbox output end right of main output flange										
Vorg_x [ mm ]: 591,00		Vorg_y [ mm ]: 115,00		Vorg_z [ mm ]: -46,50		Gearbox flange diameter [ mm ]: 120,00				
Designation	Direct. of rotation	Speed factor f	Torque [ Nm ]	Flange diameter [ mm ]	Operating period	Installed position	Fig.	NA_x [ mm ]	NA_y [ mm ]	NA_z [ mm ]
NH/1b	right	0,53	800	90,00	D	coaxial	5	110,00	0,00	0,00
NH/1c	right	0,53	800		D	coaxial	5	52,00	0,00	0,00
NH/4b	left	0,68	430	90,00	K<60 min	above	6	142,00	30,00	74,50
NH/4b	left	0,68	430	90,00	K<60 min	right	7	142,00	74,00	-30,00
NH/4b	left	0,68	430	90,00	K<60 min	below	8	142,00	-30,00	-74,50
NH/4c	left	0,68	430		K<60 min	above	6	99,00	30,00	74,50
NH/4c	left	0,68	430		K<60 min	right	7	99,00	74,00	-30,00
NH/4c	left	0,68	430		K<60 min	below	8	99,00	-30,00	-74,50

Position: Gearbox output end right of main output flange										
Vorg_x [ mm ]: 591,00		Vorg_y [ mm ]: 115,00		Vorg_z [ mm ]: -46,50		Gearbox flange diameter [ mm ]: 150,00				
Designation	Direct. of rotation	Speed factor f	Torque [ Nm ]	Flange diameter [ mm ]	Operating period	Installed position	Fig.	NA_x [ mm ]	NA_y [ mm ]	NA_z [ mm ]
NH/1b	right	0,53	800	90,00	D	coaxial	5	110,00	0,00	0,00
NH/1c	right	0,53	800		D	coaxial	5	52,00	0,00	0,00
NH/4b	left	0,68	430	90,00	K<60 min	above	6	142,00	30,00	74,50
NH/4b	left	0,68	430	90,00	K<60 min	right	7	142,00	74,00	-30,00
NH/4b	left	0,68	430	90,00	K<60 min	below	8	142,00	-30,00	-74,50
NH/4c	left	0,68	430		K<60 min	above	6	99,00	30,00	74,50
NH/4c	left	0,68	430		K<60 min	right	7	99,00	74,00	-30,00
NH/4c	left	0,68	430		K<60 min	below	8	99,00	-30,00	-74,50

Power take-offs for gearbox:							6S-850 (Standard) 6,72 – 0,79			
Position: Gearbox output end right of main output flange										
Vorg_x [ mm ]: 626,00		Vorg_y [ mm ]: 120,00		Vorg_z [ mm ]: 0,00		Gearbox flange diameter [ mm ]: 120,00				
Designation	Direct. of rotation	Speed factor f	Torque [ Nm ]	Flange diameter [ mm ]	Operating period	Installed position	Fig. <span style="border: 1px solid red; padding: 0 2px;">a</span>	NA_x [ mm ]	NA_y [ mm ]	NA_z [ mm ]
N36/5b above	left	1,47	300	90,00	K<60 min	above	9	140,00	0,00	95,00
N36/5b above	left	1,11	400	90,00	K<60 min	above	9	140,00	0,00	95,00
N36/5b below	left	1,47	300	90,00	K<60 min	below	10	140,00	0,00	-95,00
N36/5b below	left	1,11	400	90,00	K<60 min	below	10	140,00	0,00	-95,00
N36/5c above	left	1,47	300		K<60 min	above	9	94,00	0,00	95,00
N36/5c above	left	1,11	400		K<60 min	above	9	94,00	0,00	95,00
N36/5c below	left	1,47	300		K<60 min	below	10	94,00	0,00	-95,00
N36/5c below	left	1,11	400		K<60 min	below	10	94,00	0,00	-95,00
N850/10b above	left	1,72	290	100,00	D	above	11	165,00	-10,00	112,00
N850/10b above	left	1,27	430	100,00	D	above	11	165,00	-10,00	112,00
N850/10b above	left	0,97	560	100,00	D	above	11	165,00	-10,00	112,00
N850/10c above	left	1,72	290		D	above	11	118,00	-10,00	112,00
N850/10c above	left	1,27	430		D	above	11	118,00	-10,00	112,00
N850/10c above	left	0,97	560		D	above	11	118,00	-10,00	112,00
NL/1b	right	0,53	600	90,00	D	coaxial	5	110,00	0,00	0,00
NL/1b on N850/10 above	right	0,53	600	90,00	D	coaxial	12	246,00	0,00	0,00
NL/1c	right	0,53	600		D	coaxial	5	52,00	0,00	0,00
NL/1c on N850/10 above	right	0,53	600		D	coaxial	12	188,00	0,00	0,00
NL/4b	left	0,68	430	90,00	K<60 min	above	6	142,00	0,00	80,00
NL/4b	left	0,68	430	90,00	K<60 min	right	7	142,00	80,00	0,00
NL/4b	left	0,68	430	90,00	K<60 min	below	8	142,00	0,00	-80,00
NL/4b on N850/10 above	left	0,68	430	90,00	K<60 min	right	13	278,00	80,00	0,00
NL/4b on N850/10 above	left	0,68	430	90,00	K<60 min	below	14	278,00	0,00	-80,00
NL/4c	left	0,68	430		K<60 min	above	6	99,00	0,00	80,00
NL/4c	left	0,68	430		K<60 min	right	7	99,00	80,00	0,00
NL/4c	left	0,68	430		K<60 min	below	8	99,00	0,00	-80,00
NL/4c on N850/10 above	left	0,68	430		K<60 min	right	13	235,00	80,00	0,00
NL/4c on N850/10 above	left	0,68	430		K<60 min	below	14	235,00	0,00	-80,00

Power take-offs for gearbox:							6S-850 (Standard) 6,72 – 0,79			
Position: Gearbox output end right of main output flange										
Vorg_x [ mm ]: 626,00		Vorg_y [ mm ]: 120,00		Vorg_z [ mm ]: 0,00		Gearbox flange diameter [ mm ]: 150,00				
Designation	Direct. of rotation	Speed factor f	Torque [ Nm ]	Flange diameter [ mm ]	Operating period	Installed position	Fig. <span style="border: 1px solid red; padding: 0 2px;">a</span>	NA_x [ mm ]	NA_y [ mm ]	NA_z [ mm ]
N36/5b above	left	1,47	300	90,00	K<60 min	above	9	140,00	0,00	95,00
N36/5b above	left	1,11	400	90,00	K<60 min	above	9	140,00	0,00	95,00
N36/5b below	left	1,47	300	90,00	K<60 min	below	10	140,00	0,00	-95,00
N36/5b below	left	1,11	400	90,00	K<60 min	below	10	140,00	0,00	-95,00
N36/5c above	left	1,47	300		K<60 min	above	9	94,00	0,00	95,00
N36/5c above	left	1,11	400		K<60 min	above	9	94,00	0,00	95,00
N36/5c below	left	1,47	300		K<60 min	below	10	94,00	0,00	-95,00
N36/5c below	left	1,11	400		K<60 min	below	10	94,00	0,00	-95,00
N850/10b above	left	1,72	290	100,00	D	above	11	165,00	-10,00	112,00
N850/10b above	left	1,27	430	100,00	D	above	11	165,00	-10,00	112,00
N850/10b above	left	0,97	560	100,00	D	above	11	165,00	-10,00	112,00
N850/10c above	left	1,72	290		D	above	11	118,00	-10,00	112,00
N850/10c above	left	1,27	430		D	above	11	118,00	-10,00	112,00
N850/10c above	left	0,97	560		D	above	11	118,00	-10,00	112,00
NL/1b	right	0,53	600	90,00	D	coaxial	5	110,00	0,00	0,00
NL/1c	right	0,53	600		D	coaxial	5	52,00	0,00	0,00
NL/4b	left	0,68	430	90,00	K<60 min	above	6	142,00	0,00	80,00
NL/4b	left	0,68	430	90,00	K<60 min	right	7	142,00	80,00	0,00
NL/4b	left	0,68	430	90,00	K<60 min	below	8	142,00	0,00	-80,00
NL/4c	left	0,68	430		K<60 min	above	6	99,00	0,00	80,00
NL/4c	left	0,68	430		K<60 min	right	7	99,00	80,00	0,00
NL/4c	left	0,68	430		K<60 min	below	8	99,00	0,00	-80,00

**Ecomid** a

Power take-offs for gearbox:							<span style="border: 1px solid black; padding: 0 2px;">a</span> 9S-1310 TO (Standard) 9,48 – 0,75			
Position: Gearbox output end right of main output flange										
Vorg_x [ mm ]: 737,00		Vorg_y [ mm ]: 208,00		Vorg_z [ mm ]: -51,00		Gearbox flange diameter [ mm ]: 150,00				
Designation	Direct. of rotation	Speed factor f	Torque [ Nm ]	Flange diameter [ mm ]	Operating period	Installed position	Fig.	NA_x [ mm ]	NA_y [ mm ]	NA_z [ mm ]
N109/10b above	left	1,90	410	100	K<60 min#	above	15	137,0	0,0	113,0
N109/10b above	left	1,46	530	100	K<60 min#	above	15	137,0	0,0	113,0
N109/10b above	left	1,18	630	100	K<60 min#	above	15	137,0	0,0	113,0
N109/10c above	left	1,46	530		K<60 min#	above	15	143,0	0,0	113,0
N109/10c above	left	1,18	630		K<60 min#	above	15	143,0	0,0	113,0
NH/1b	right	0,97	800	90	D	coaxial	5	110,0	0,0	0,0
NH/1c	right	0,97	800		D	coaxial	5	52,0	0,0	0,0
NH/4b	left	1,24	430	90	K<60 min	above	6	142,0	0,0	80,0
NH/4b	left	1,24	430	90	K<60 min	right	7	142,0	80,0	0,0
NH/4b	left	1,24	430	90	K<60 min	below	8	142,0	0,0	-80,0
NH/4c	left	1,24	430		K<60 min	above	6	99,0	0,0	80,0
NH/4c	left	1,24	430		K<60 min	right	7	99,0	80,0	0,0
NH/4c	left	1,24	430		K<60 min	below	8	99,0	0,0	-80,0

## # Continuous operation:

- with fan(for flange)
- with use of <=80% of max permissible torque

## Ecosplit

Power take-offs for gearbox:								16S-1820 TO (Standard) 13,8 – 0,84 16S-1823 TO (Standard+100%Push) 13,8 – 0,84			
Position: Gearbox output end right of main output flange											
Vorg_x [ mm ]: 832,00			Vorg_y [ mm ]: 154,00			Vorg_z [ mm ]: 10,00			Gearbox flange diameter [ mm ]: 180,00		
Designation	Direct. of rotation	Speed factor f		Torque [ Nm ]	Flange diameter [ mm ]	Operating period	Installed position	Fig. <span style="border: 1px solid black; padding: 0 2px;">a</span>	NA_x [ mm ]	NA_y [ mm ]	NA_z [ mm ]
		L	S								
N221/10b above	left	1,99	2,39	470	100,00	D	above	16	176,00	8,00	113,00
N221/10b above	left	1,74	2,08	560	100,00	D	above	16	176,00	8,00	113,00
N221/10b above	left	1,35	1,61	730	100,00	D	above	16	176,00	8,00	113,00
N221/10b above	left	1,12	1,34	870	100,00	D	above	16	176,00	8,00	113,00
N221/10b below	left	1,99	2,39	470	100,00	D	below	20	176,00	8,00	-113,00
N221/10b below	left	1,74	2,08	560	100,00	D	below	20	176,00	8,00	-113,00
N221/10b below	left	1,35	1,61	730	100,00	D	below	20	176,00	8,00	-113,00
N221/10b below	left	1,12	1,34	870	100,00	D	below	20	176,00	8,00	-113,00
N221/10c above	left	1,99	2,39	470		D	above	16	136,00	8,00	113,00
N221/10c above	left	1,74	2,08	560		D	above	16	136,00	8,00	113,00
N221/10c above	left	1,35	1,61	730		D	above	16	136,00	8,00	113,00
N221/10c above	left	1,12	1,34	870		D	above	16	136,00	8,00	113,00
N221/10c below	left	1,99	2,39	470		D	below	20	136,00	8,00	-113,00
N221/10c below	left	1,74	2,08	560		D	below	20	136,00	8,00	-113,00
N221/10c below	left	1,35	1,61	730		D	below	20	136,00	8,00	-113,00
N221/10c below	left	1,12	1,34	870		D	below	20	136,00	8,00	-113,00
NH/1b	right	0,91	1,09	1000	90,00	D	coaxial	5	110,00	0,00	0,00
NH/1c	right	0,91	1,09	1000		D	coaxial	5	52,00	0,00	0,00
NH/4b	left	1,16	1,40	430	90,00	K<60 min	above	6	142,00	0,00	80,00
NH/4b	left	1,16	1,40	430	90,00	K<60 min	right	7	142,00	80,00	0,00
NH/4b	left	1,16	1,40	430	90,00	K<60 min	below	8	142,00	0,00	-80,00
NH/4c	left	1,16	1,40	430		K<60 min	above	6	99,00	0,00	80,00
NH/4c	left	1,16	1,40	430		K<60 min	right	7	99,00	80,00	0,00
NH/4c	left	1,16	1,40	430		K<60 min	below	8	99,00	0,00	-80,00
NL/1b on N221/10 above	right	0,91	1,09	600	90,00	D	coaxial	17	264,00	0,00	0,00
NL/1b on N221/10 below	right	0,91	1,09	600	90,00	D	coaxial	21	264,00	0,00	0,00
NL/1c on N221/10 above	right	0,91	1,09	600		D	coaxial	17	206,00	0,00	0,00
NL/1c on N221/10 below	right	0,91	1,09	600		D	coaxial	21	206,00	0,00	0,00
NL/4b on N221/10 above	left	1,16	1,40	430	90,00	K<60 min	right	18	296,00	80,00	0,00
NL/4b on N221/10 above	left	1,16	1,40	430	90,00	K<60 min	below	19	296,00	0,00	-80,00
NL/4b on N221/10 below	left	1,16	1,40	430	90,00	K<60 min	above	23	296,00	0,00	80,00
NL/4b on N221/10 below	left	1,16	1,40	430	90,00	K<60 min	right	22	296,00	80,00	0,00
NL/4c on N221/10 above	left	1,16	1,40	430		K<60 min	right	18	253,00	80,00	0,00
NL/4c on N221/10 above	left	1,16	1,40	430		K<60 min	below	19	253,00	0,00	-80,00
NL/4c on N221/10 below	left	1,16	1,40	430		K<60 min	above	23	253,00	0,00	80,00
NL/4c on N221/10 below	left	1,16	1,40	430		K<60 min	right	22	253,00	80,00	0,00

Power take-offs for gearbox:							16S-1821 TO (with Intarder) 13,8 – 0,84				
Position: Gearbox output end right of main output flange											
Vorg_x [ mm ]: 832,00		Vorg_y [ mm ]: 154,00		Vorg_z [ mm ]: 10,00		Gearbox flange diameter [ mm ]: 180,00					
Designation	Direct. of rotation	Speed factor f		Torque [ Nm ]	Flange diameter [ mm ]	Operating period	Installed position	Fig. <span style="border: 1px solid red; padding: 0 2px;">a</span>	NA_x [ mm ]	NA_y [ mm ]	NA_z [ mm ]
		L	S								
N221/10b-IT above	left	1,99	2,39	470	100,00	D	above	16	176,00	8,00	113,00
N221/10b-IT above	left	1,74	2,08	560	100,00	D	above	16	176,00	8,00	113,00
N221/10b-IT above	left	1,35	1,61	730	100,00	D	above	16	176,00	8,00	113,00
N221/10b-IT above	left	1,12	1,34	870	100,00	D	above	16	176,00	8,00	113,00
N221/10b-IT below	left	1,99	2,39	470	100,00	D	below	20	176,00	8,00	-113,00
N221/10b-IT below	left	1,74	2,08	560	100,00	D	below	20	176,00	8,00	-113,00
N221/10b-IT below	left	1,35	1,61	730	100,00	D	below	20	176,00	8,00	-113,00
N221/10b-IT below	left	1,12	1,34	870	100,00	D	below	20	176,00	8,00	-113,00
N221/10c-IT above	left	1,99	2,39	470		D	above	16	136,00	8,00	113,00
N221/10c-IT above	left	1,74	2,08	560		D	above	16	136,00	8,00	113,00
N221/10c-IT above	left	1,35	1,61	730		D	above	16	136,00	8,00	113,00
N221/10c-IT above	left	1,12	1,34	870		D	above	16	136,00	8,00	113,00
N221/10c-IT below	left	1,99	2,39	470		D	below	20	136,00	8,00	-113,00
N221/10c-IT below	left	1,74	2,08	560		D	below	20	136,00	8,00	-113,00
N221/10c-IT below	left	1,35	1,61	730		D	below	20	136,00	8,00	-113,00
N221/10c-IT below	left	1,12	1,34	870		D	below	20	136,00	8,00	-113,00
NH/1b-IT	right	0,91	1,09	1000	90,00	D	coaxial	5	146,50	0,00	0,00
NH/1c-IT	right	0,91	1,09	1000		D	coaxial	5	88,50	0,00	0,00
NH/4b-IT	left	1,16	1,40	430	90,00	K<60 min	above	6	178,50	0,00	80,00
NH/4b-IT	left	1,16	1,40	430	90,00	K<60 min	right	7	178,50	80,00	0,00
NH/4b-IT	left	1,16	1,40	430	90,00	K<60 min	below	8	178,50	0,00	-80,00
NH/4c-IT	left	1,16	1,40	430		K<60 min	above	6	135,50	0,00	80,00
NH/4c-IT	left	1,16	1,40	430		K<60 min	right	7	135,50	80,00	0,00
NH/4c-IT	left	1,16	1,40	430		K<60 min	below	8	135,50	0,00	-80,00
NL/1b on N221/10-IT above	right	0,91	1,09	600	90,00	D	coaxial	17	264,00	0,00	0,00
NL/1b on N221/10-IT below	right	0,91	1,09	600	90,00	D	coaxial	21	264,00	0,00	0,00
NL/1c on N221/10-IT above	right	0,91	1,09	600		D	coaxial	17	206,00	0,00	0,00
NL/1c on N221/10-IT below	right	0,91	1,09	600		D	coaxial	21	206,00	0,00	0,00
NL/4b on N221/10-IT above	left	1,16	1,40	430	90,00	K<60 min	right	18	296,00	80,00	0,00
NL/4b on N221/10-IT above	left	1,16	1,40	430	90,00	K<60 min	below	19	296,00	0,00	-80,00
NL/4b on N221/10-IT below	left	1,16	1,40	430	90,00	K<60 min	above	23	296,00	0,00	80,00
NL/4b on N221/10-IT below	left	1,16	1,40	430	90,00	K<60 min	right	22	296,00	80,00	0,00
NL/4c on N221/10-IT above	left	1,16	1,40	430		K<60 min	right	18	253,00	80,00	0,00
NL/4c on N221/10-IT above	left	1,16	1,40	430		K<60 min	below	19	253,00	0,00	-80,00
NL/4c on N221/10-IT below	left	1,16	1,40	430		K<60 min	above	23	253,00	0,00	80,00
NL/4c on N221/10-IT below	left	1,16	1,40	430		K<60 min	right	22	253,00	80,00	0,00

Power take-offs for gearbox: <span style="float: right;">16S-1822 TO (with NMV) 13,8 – 0,84</span>											
Position: Gearbox output end right of main output flange											
Vorg_x [ mm ]: 952,00		Vorg_y [ mm ]: 154,00		Vorg_z [ mm ]: 10,00		Gearbox flange diameter [ mm ]: 180,00					
Designation	Direct. of rotation	Speed factor f		Torque [ Nm ]	Flange diameter [ mm ]	Operating period	Installed position	Fig. <span style="border: 1px solid black; padding: 0 2px;">a</span>	NA_x [ mm ]	NA_y [ mm ]	NA_z [ mm ]
		L	S								
N221/10b above	left	1,99	2,39	470	100,00	D	above	16	176,00	8,00	113,00
N221/10b above	left	1,74	2,08	560	100,00	D	above	16	176,00	8,00	113,00
N221/10b above	left	1,35	1,61	730	100,00	D	above	16	176,00	8,00	113,00
N221/10b above	left	1,12	1,34	870	100,00	D	above	16	176,00	8,00	113,00
N221/10b below	left	1,99	2,39	470	100,00	D	below	20	176,00	8,00	-113,00
N221/10b below	left	1,74	2,08	560	100,00	D	below	20	176,00	8,00	-113,00
N221/10b below	left	1,35	1,61	730	100,00	D	below	20	176,00	8,00	-113,00
N221/10b below	left	1,12	1,34	870	100,00	D	below	20	176,00	8,00	-113,00
N221/10c above	left	1,99	2,39	470		D	above	16	136,00	8,00	113,00
N221/10c above	left	1,74	2,08	560		D	above	16	136,00	8,00	113,00
N221/10c above	left	1,35	1,61	730		D	above	16	136,00	8,00	113,00
N221/10c above	left	1,12	1,34	870		D	above	16	136,00	8,00	113,00
N221/10c below	left	1,99	2,39	470		D	below	20	136,00	8,00	-113,00
N221/10c below	left	1,74	2,08	560		D	below	20	136,00	8,00	-113,00
N221/10c below	left	1,35	1,61	730		D	below	20	136,00	8,00	-113,00
N221/10c below	left	1,12	1,34	870		D	below	20	136,00	8,00	-113,00
NH/1b	right	0,91	1,09	1000	90,00	D	coaxial	5	110,00	0,00	0,00
NH/1c	right	0,91	1,09	1000		D	coaxial	5	52,00	0,00	0,00
NH/4b	left	1,16	1,40	430	90,00	K<60 min	above	6	142,00	0,00	80,00
NH/4b	left	1,16	1,40	430	90,00	K<60 min	right	7	142,00	80,00	0,00
NH/4b	left	1,16	1,40	430	90,00	K<60 min	below	8	142,00	0,00	-80,00
NH/4c	left	1,16	1,40	430		K<60 min	above	6	99,00	0,00	80,00
NH/4c	left	1,16	1,40	430		K<60 min	right	7	99,00	80,00	0,00
NH/4c	left	1,16	1,40	430		K<60 min	below	8	99,00	0,00	-80,00
NL/1b on N221/10 above	right	0,91	1,09	600	90,00	D	coaxial	17	264,00	0,00	0,00
NL/1b on N221/10 below	right	0,91	1,09	600	90,00	D	coaxial	21	264,00	0,00	0,00
NL/1c on N221/10 above	right	0,91	1,09	600		D	coaxial	17	206,00	0,00	0,00
NL/1c on N221/10 below	right	0,91	1,09	600		D	coaxial	21	206,00	0,00	0,00
NL/4b on N221/10 above	left	1,16	1,40	430	90,00	K<60 min	right	18	296,00	80,00	0,00
NL/4b on N221/10 above	left	1,16	1,40	430	90,00	K<60 min	below	19	296,00	0,00	-80,00
NL/4b on N221/10 below	left	1,16	1,40	430	90,00	K<60 min	above	23	296,00	0,00	80,00
NL/4b on N221/10 below	left	1,16	1,40	430	90,00	K<60 min	right	22	296,00	80,00	0,00
NL/4c on N221/10 above	left	1,16	1,40	430		K<60 min	right	18	253,00	80,00	0,00
NL/4c on N221/10 above	left	1,16	1,40	430		K<60 min	below	19	253,00	0,00	-80,00
NL/4c on N221/10 below	left	1,16	1,40	430		K<60 min	above	23	253,00	0,00	80,00
NL/4c on N221/10 below	left	1,16	1,40	430		K<60 min	right	22	253,00	80,00	0,00
Position: Flywheel											
Vorg_x [ mm ]: 0,00		Vorg_y [ mm ]: 0,00		Vorg_z [ mm ]: 0,00							
Designation	Direct. of rotation	Speed factor f		Torque [ Nm ]	Flange diameter [ mm ]	Operating period	Installed position	Fig. <span style="border: 1px solid black; padding: 0 2px;">a</span>	NA_x [ mm ]	NA_y [ mm ]	NA_z [ mm ]
		L	S								
NMV221	left	1,54		1300	150,00	D	above	1	435,00	38,00	300,00
NMV221	left	0,98		2000	150,00	D	above	1	435,00	38,00	300,00

Power take-offs for gearbox:											
<b>16S-1920 TD (Standard) 16,41 – 1</b> <b>16S-1923 TD (Standard+100%Push) 16,41 – 1</b> <b>16S-2220 TD (Standard) 16,41 – 1</b> <b>16S-2223 TD (Standard+100%Push) 16,41 – 1</b> <b>16S-2320 TD (Standard) 16,41 – 1</b> <b>16S-2323 TD (Standard+100%Push) 16,41 – 1</b>											
Position: Gearbox output end right of main output flange											
Vorg_x [ mm ]: 917,00			Vorg_y [ mm ]: 154,00			Vorg_z [ mm ]: 10,00		Gearbox flange diameter [ mm ]: 180,00			
Designation	Direct. of rotation	Speed factor f		Torque [ Nm ]	Flange diameter [ mm ]	Operating period	Installed position	Fig. <span style="border: 1px solid black; padding: 0 2px;">a</span>	NA_x [ mm ]	NA_y [ mm ]	NA_z [ mm ]
		L	S								
N221/10b above	left	1,69	1,99	470	100,00	D	above	16	176,00	8,00	113,00
N221/10b above	left	1,47	1,74	560	100,00	D	above	16	176,00	8,00	113,00
N221/10b above	left	1,14	1,35	730	100,00	D	above	16	176,00	8,00	113,00
N221/10b above	left	0,95	1,12	870	100,00	D	above	16	176,00	8,00	113,00
N221/10b below	left	1,69	1,99	470	100,00	D	below	20	176,00	8,00	-113,00
N221/10b below	left	1,47	1,74	560	100,00	D	below	20	176,00	8,00	-113,00
N221/10b below	left	1,14	1,35	730	100,00	D	below	20	176,00	8,00	-113,00
N221/10b below	left	0,95	1,12	870	100,00	D	below	20	176,00	8,00	-113,00
N221/10c above	left	1,69	1,99	470		D	above	16	136,00	8,00	113,00
N221/10c above	left	1,47	1,74	560		D	above	16	136,00	8,00	113,00
N221/10c above	left	1,14	1,35	730		D	above	16	136,00	8,00	113,00
N221/10c above	left	0,95	1,12	870		D	above	16	136,00	8,00	113,00
N221/10c below	left	1,69	1,99	470		D	below	20	136,00	8,00	-113,00
N221/10c below	left	1,47	1,74	560		D	below	20	136,00	8,00	-113,00
N221/10c below	left	1,14	1,35	730		D	below	20	136,00	8,00	-113,00
N221/10c below	left	0,95	1,12	870		D	below	20	136,00	8,00	-113,00
NH/1b	right	0,77	0,91	1000	90,00	D	coaxial	5	110,00	0,00	0,00
NH/1c	right	0,77	0,91	1000		D	coaxial	5	52,00	0,00	0,00
NH/4b	left	0,99	1,16	430	90,00	K<60 min	above	6	142,00	0,00	80,00
NH/4b	left	0,99	1,16	430	90,00	K<60 min	right	7	142,00	80,00	0,00
NH/4b	left	0,99	1,16	430	90,00	K<60 min	below	8	142,00	0,00	-80,00
NH/4c	left	0,99	1,16	430		K<60 min	above	6	99,00	0,00	80,00
NH/4c	left	0,99	1,16	430		K<60 min	right	7	99,00	80,00	0,00
NH/4c	left	0,99	1,16	430		K<60 min	below	8	99,00	0,00	-80,00
NL/1b on N221/10 above	right	0,77	0,91	600	90,00	D	coaxial	17	264,00	0,00	0,00
NL/1b on N221/10 below	right	0,77	0,91	600	90,00	D	coaxial	21	264,00	0,00	0,00
NL/1c on N221/10 above	right	0,77	0,91	600		D	coaxial	17	206,00	0,00	0,00
NL/1c on N221/10 below	right	0,77	0,91	600		D	coaxial	21	206,00	0,00	0,00
NL/4b on N221/10 above	left	0,99	1,16	430	90,00	K<60 min	right	18	296,00	80,00	0,00
NL/4b on N221/10 above	left	0,99	1,16	430	90,00	K<60 min	below	19	296,00	0,00	-80,00
NL/4b on N221/10 below	left	0,99	1,16	430	90,00	K<60 min	above	23	296,00	0,00	80,00
NL/4b on N221/10 below	left	0,99	1,16	430	90,00	K<60 min	right	22	296,00	80,00	0,00
NL/4c on N221/10 above	left	0,99	1,16	430		K<60 min	right	18	253,00	80,00	0,00
NL/4c on N221/10 above	left	0,99	1,16	430		K<60 min	below	19	253,00	0,00	-80,00
NL/4c on N221/10 below	left	0,99	1,16	430		K<60 min	above	23	253,00	0,00	80,00
NL/4c on N221/10 below	left	0,99	1,16	430		K<60 min	right	22	253,00	80,00	0,00

Power take-offs for gearbox:								16S-1921 TD (with Intarder) 16,41 – 1			
								16S-2221 TD (with Intarder) 16,41 – 1			
								16S-2321 TD (with Intarder) 16,41 – 1			
Position: Gearbox output end right of main output flange											
Vorg_x [ mm ]: 917,00			Vorg_y [ mm ]: 154,00			Vorg_z [ mm ]: 10,00			Gearbox flange diameter [ mm ]: 180,00		
Designation	Direct. of rotation	Speed factor f		Torque [ Nm ]	Flange diameter [ mm ]	Operating period	Installed position	Fig. <span style="border: 1px solid black; padding: 0 2px;">a</span>	NA_x	NA_y	NA_z
		L	S						[ mm ]	[ mm ]	[ mm ]
N221/10b-IT above	left	1,69	1,99	470	100,00	D	above	16	176,00	8,00	113,00
N221/10b-IT above	left	1,47	1,74	560	100,00	D	above	16	176,00	8,00	113,00
N221/10b-IT above	left	1,14	1,35	730	100,00	D	above	16	176,00	8,00	113,00
N221/10b-IT above	left	0,95	1,12	870	100,00	D	above	16	176,00	8,00	113,00
N221/10b-IT below	left	1,69	1,99	470	100,00	D	below	20	176,00	8,00	-113,00
N221/10b-IT below	left	1,47	1,74	560	100,00	D	below	20	176,00	8,00	-113,00
N221/10b-IT below	left	1,14	1,35	730	100,00	D	below	20	176,00	8,00	-113,00
N221/10b-IT below	left	0,95	1,12	870	100,00	D	below	20	176,00	8,00	-113,00
N221/10c-IT above	left	1,69	1,99	470		D	above	16	136,00	8,00	113,00
N221/10c-IT above	left	1,47	1,74	560		D	above	16	136,00	8,00	113,00
N221/10c-IT above	left	1,14	1,35	730		D	above	16	136,00	8,00	113,00
N221/10c-IT above	left	0,95	1,12	870		D	above	16	136,00	8,00	113,00
N221/10c-IT below	left	1,69	1,99	470		D	below	20	136,00	8,00	-113,00
N221/10c-IT below	left	1,47	1,74	560		D	below	20	136,00	8,00	-113,00
N221/10c-IT below	left	1,14	1,35	730		D	below	20	136,00	8,00	-113,00
N221/10c-IT below	left	0,95	1,12	870		D	below	20	136,00	8,00	-113,00
NH/1b-IT	right	0,77	0,91	1000	90,00	D	coaxial	5	146,50	0,00	0,00
NH/1c-IT	right	0,77	0,91	1000		D	coaxial	5	88,50	0,00	0,00
NH/4b-IT	left	0,99	1,16	430	90,00	K<60 min	above	6	178,50	0,00	80,00
NH/4b-IT	left	0,99	1,16	430	90,00	K<60 min	right	7	178,50	80,00	0,00
NH/4b-IT	left	0,99	1,16	430	90,00	K<60 min	below	8	178,50	0,00	-80,00
NH/4c-IT	left	0,99	1,16	430		K<60 min	above	6	135,50	0,00	80,00
NH/4c-IT	left	0,99	1,16	430		K<60 min	right	7	135,50	80,00	0,00
NH/4c-IT	left	0,99	1,16	430		K<60 min	below	8	135,50	0,00	-80,00
NL/1b on N221/10-IT above	right	0,77	0,91	600	90,00	D	coaxial	17	264,00	0,00	0,00
NL/1b on N221/10-IT below	right	0,77	0,91	600	90,00	D	coaxial	21	264,00	0,00	0,00
NL/1c on N221/10-IT above	right	0,77	0,91	600		D	coaxial	17	206,00	0,00	0,00
NL/1c on N221/10-IT below	right	0,77	0,91	600		D	coaxial	21	206,00	0,00	0,00
NL/4b on N221/10-IT above	left	0,99	1,16	430	90,00	K<60 min	right	18	296,00	80,00	0,00
NL/4b on N221/10-IT above	left	0,99	1,16	430	90,00	K<60 min	below	19	296,00	0,00	-80,00
NL/4b on N221/10-IT below	left	0,99	1,16	430	90,00	K<60 min	above	23	296,00	0,00	80,00
NL/4b on N221/10-IT below	left	0,99	1,16	430	90,00	K<60 min	right	22	296,00	80,00	0,00
NL/4c on N221/10-IT above	left	0,99	1,16	430		K<60 min	right	18	253,00	80,00	0,00
NL/4c on N221/10-IT above	left	0,99	1,16	430		K<60 min	below	19	253,00	0,00	-80,00
NL/4c on N221/10-IT below	left	0,99	1,16	430		K<60 min	above	23	253,00	0,00	80,00
NL/4c on N221/10-IT below	left	0,99	1,16	430		K<60 min	right	22	253,00	80,00	0,00

Power take-offs for gearbox:											16S-2220 TO (Standard) 13,8 – 0,84	
											16S-2223 TO (Standard+100% Push) 13,8 – 0,84	
											16S-2520 TO (Standard) 13,8 – 0,84	
											16S-2523 TO (Standard+100% Push) 13,8 – 0,84	
Position: Gearbox output end right of main output flange												
Vorg_x [ mm ]: 917,00			Vorg_y [ mm ]: 154,00			Vorg_z [ mm ]: 10,00			Gearbox flange diameter [ mm ]: 180,00			
Designation	Direct. of rotation	Speed factor f		Torque [ Nm ]	Flange diameter [ mm ]	Operating period	Installed position	Fig. <span style="border: 1px solid black; padding: 0 2px;">a</span>	NA_x [ mm ]	NA_y [ mm ]	NA_z [ mm ]	
		L	S									
N221/10b above	left	1,99	2,39	470	100,00	D	above	16	176,00	8,00	113,00	
N221/10b above	left	1,74	2,08	560	100,00	D	above	16	176,00	8,00	113,00	
N221/10b above	left	1,35	1,61	730	100,00	D	above	16	176,00	8,00	113,00	
N221/10b above	left	1,12	1,34	870	100,00	D	above	16	176,00	8,00	113,00	
N221/10b below	left	1,99	2,39	470	100,00	D	below	20	176,00	8,00	-113,00	
N221/10b below	left	1,74	2,08	560	100,00	D	below	20	176,00	8,00	-113,00	
N221/10b below	left	1,35	1,61	730	100,00	D	below	20	176,00	8,00	-113,00	
N221/10b below	left	1,12	1,34	870	100,00	D	below	20	176,00	8,00	-113,00	
N221/10c above	left	1,99	2,39	470		D	above	16	136,00	8,00	113,00	
N221/10c above	left	1,74	2,08	560		D	above	16	136,00	8,00	113,00	
N221/10c above	left	1,35	1,61	730		D	above	16	136,00	8,00	113,00	
N221/10c above	left	1,12	1,34	870		D	above	16	136,00	8,00	113,00	
N221/10c below	left	1,99	2,39	470		D	below	20	136,00	8,00	-113,00	
N221/10c below	left	1,74	2,08	560		D	below	20	136,00	8,00	-113,00	
N221/10c below	left	1,35	1,61	730		D	below	20	136,00	8,00	-113,00	
N221/10c below	left	1,12	1,34	870		D	below	20	136,00	8,00	-113,00	
NH/1b	right	0,91	1,09	1000	90,00	D	coaxial	5	110,00	0,00	0,00	
NH/1c	right	0,91	1,09	1000		D	coaxial	5	52,00	0,00	0,00	
NH/4b	left	1,16	1,40	430	90,00	K<60 min	above	6	142,00	0,00	80,00	
NH/4b	left	1,16	1,40	430	90,00	K<60 min	right	7	142,00	80,00	0,00	
NH/4b	left	1,16	1,40	430	90,00	K<60 min	below	8	142,00	0,00	-80,00	
NH/4c	left	1,16	1,40	430		K<60 min	above	6	99,00	0,00	80,00	
NH/4c	left	1,16	1,40	430		K<60 min	right	7	99,00	80,00	0,00	
NH/4c	left	1,16	1,40	430		K<60 min	below	8	99,00	0,00	-80,00	
NL/1b on N221/10 above	right	0,91	1,09	600	90,00	D	coaxial	17	264,00	0,00	0,00	
NL/1b on N221/10 below	right	0,91	1,09	600	90,00	D	coaxial	21	264,00	0,00	0,00	
NL/1c on N221/10 above	right	0,91	1,09	600		D	coaxial	17	206,00	0,00	0,00	
NL/1c on N221/10 below	right	0,91	1,09	600		D	coaxial	21	206,00	0,00	0,00	
NL/4b on N221/10 above	left	1,16	1,40	430	90,00	K<60 min	right	18	296,00	80,00	0,00	
NL/4b on N221/10 above	left	1,16	1,40	430	90,00	K<60 min	below	19	296,00	0,00	-80,00	
NL/4b on N221/10 below	left	1,16	1,40	430	90,00	K<60 min	above	23	296,00	0,00	80,00	
NL/4b on N221/10 below	left	1,16	1,40	430	90,00	K<60 min	right	22	296,00	80,00	0,00	
NL/4c on N221/10 above	left	1,16	1,40	430		K<60 min	right	18	253,00	80,00	0,00	
NL/4c on N221/10 above	left	1,16	1,40	430		K<60 min	below	19	253,00	0,00	-80,00	
NL/4c on N221/10 below	left	1,16	1,40	430		K<60 min	above	23	253,00	0,00	80,00	
NL/4c on N221/10 below	left	1,16	1,40	430		K<60 min	right	22	253,00	80,00	0,00	

Power take-offs for gearbox:								<b>16S-2221 TO (with Intarder) 13,8 – 0,84</b>			
								<b>16S-2521 TO (with Intarder) 13,8 – 0,84</b>			
Position: Gearbox output end right of main output flange											
Vorg_x [ mm ]: 917,00		Vorg_y [ mm ]: 154,00		Vorg_z [ mm ]: 10,00		Gearbox flange diameter [ mm ]: 180,00					
Designation	Direct. of rotation	Speed factor f		Torque [ Nm ]	Flange diameter [ mm ]	Operating period	Installed position	Fig. <span style="border: 1px solid black; padding: 0 2px;">a</span>	NA_x [ mm ]	NA_y [ mm ]	NA_z [ mm ]
		L	S								
N221/10b-IT above	left	1,99	2,39	470	100,00	D	above	16	176,00	8,00	113,00
N221/10b-IT above	left	1,74	2,08	560	100,00	D	above	16	176,00	8,00	113,00
N221/10b-IT above	left	1,35	1,61	730	100,00	D	above	16	176,00	8,00	113,00
N221/10b-IT above	left	1,12	1,34	870	100,00	D	above	16	176,00	8,00	113,00
N221/10b-IT below	left	1,99	2,39	470	100,00	D	below	20	176,00	8,00	-113,00
N221/10b-IT below	left	1,74	2,08	560	100,00	D	below	20	176,00	8,00	-113,00
N221/10b-IT below	left	1,35	1,61	730	100,00	D	below	20	176,00	8,00	-113,00
N221/10b-IT below	left	1,12	1,34	870	100,00	D	below	20	176,00	8,00	-113,00
N221/10c-IT above	left	1,99	2,39	470		D	above	16	136,00	8,00	113,00
N221/10c-IT above	left	1,74	2,08	560		D	above	16	136,00	8,00	113,00
N221/10c-IT above	left	1,35	1,61	730		D	above	16	136,00	8,00	113,00
N221/10c-IT above	left	1,12	1,34	870		D	above	16	136,00	8,00	113,00
N221/10c-IT below	left	1,99	2,39	470		D	below	20	136,00	8,00	-113,00
N221/10c-IT below	left	1,74	2,08	560		D	below	20	136,00	8,00	-113,00
N221/10c-IT below	left	1,35	1,61	730		D	below	20	136,00	8,00	-113,00
N221/10c-IT below	left	1,12	1,34	870		D	below	20	136,00	8,00	-113,00
NH/1b-IT	right	0,91	1,09	1000	90,00	D	coaxial	5	146,50	0,00	0,00
NH/1c-IT	right	0,91	1,09	1000		D	coaxial	5	88,50	0,00	0,00
NH/4b-IT	left	1,16	1,40	430	90,00	K<60 min	above	6	178,50	0,00	80,00
NH/4b-IT	left	1,16	1,40	430	90,00	K<60 min	right	7	178,50	80,00	0,00
NH/4b-IT	left	1,16	1,40	430	90,00	K<60 min	below	8	178,50	0,00	-80,00
NH/4c-IT	left	1,16	1,40	430		K<60 min	above	6	135,50	0,00	80,00
NH/4c-IT	left	1,16	1,40	430		K<60 min	right	7	135,50	80,00	0,00
NH/4c-IT	left	1,16	1,40	430		K<60 min	below	8	135,50	0,00	-80,00
NL/1b on N221/10-IT above	right	0,91	1,09	600	90,00	D	coaxial	17	264,00	0,00	0,00
NL/1b on N221/10-IT below	right	0,91	1,09	600	90,00	D	coaxial	21	264,00	0,00	0,00
NL/1c on N221/10-IT above	right	0,91	1,09	600		D	coaxial	17	206,00	0,00	0,00
NL/1c on N221/10-IT below	right	0,91	1,09	600		D	coaxial	21	206,00	0,00	0,00
NL/4b on N221/10-IT above	left	1,16	1,40	430	90,00	K<60 min	right	18	296,00	80,00	0,00
NL/4b on N221/10-IT above	left	1,16	1,40	430	90,00	K<60 min	below	19	296,00	0,00	-80,00
NL/4b on N221/10-IT below	left	1,16	1,40	430	90,00	K<60 min	above	23	296,00	0,00	80,00
NL/4b on N221/10-IT below	left	1,16	1,40	430	90,00	K<60 min	right	22	296,00	80,00	0,00
NL/4c on N221/10-IT above	left	1,16	1,40	430		K<60 min	right	18	253,00	80,00	0,00
NL/4c on N221/10-IT above	left	1,16	1,40	430		K<60 min	below	19	253,00	0,00	-80,00
NL/4c on N221/10-IT below	left	1,16	1,40	430		K<60 min	above	23	253,00	0,00	80,00
NL/4c on N221/10-IT below	left	1,16	1,40	430		K<60 min	right	22	253,00	80,00	0,00

Power take-offs for gearbox: **16S-2222 TO (with NMV / with NMV+100% Push) 13,8 – 0,84**  
**16S-2522 TO (with NMV / with NMV+100% Push) 13,8 – 0,84**

Position: Gearbox output end right of main output flange

Vorg\_x [ mm ]: 1037,00    Vorg\_y [ mm ]: 154,00    Vorg\_z [ mm ]: 10,00    Gearbox flange diameter [ mm ]: 180,00

Designation	Direct. of rotation	Speed factor f		Torque [ Nm ]	Flange diameter [ mm ]	Operating period	Installed position	Fig. <span style="border: 1px solid black; padding: 0 2px;">a</span>	NA_x [ mm ]	NA_y [ mm ]	NA_z [ mm ]
		L	S								
N221/10b above	left	1,99	2,39	470	100,00	D	above	16	176,00	8,00	113,00
N221/10b above	left	1,74	2,08	560	100,00	D	above	16	176,00	8,00	113,00
N221/10b above	left	1,35	1,61	730	100,00	D	above	16	176,00	8,00	113,00
N221/10b above	left	1,12	1,34	870	100,00	D	above	16	176,00	8,00	113,00
N221/10b below	left	1,99	2,39	470	100,00	D	below	20	176,00	8,00	-113,00
N221/10b below	left	1,74	2,08	560	100,00	D	below	20	176,00	8,00	-113,00
N221/10b below	left	1,35	1,61	730	100,00	D	below	20	176,00	8,00	-113,00
N221/10b below	left	1,12	1,34	870	100,00	D	below	20	176,00	8,00	-113,00
N221/10c above	left	1,99	2,39	470		D	above	16	136,00	8,00	113,00
N221/10c above	left	1,74	2,08	560		D	above	16	136,00	8,00	113,00
N221/10c above	left	1,35	1,61	730		D	above	16	136,00	8,00	113,00
N221/10c above	left	1,12	1,34	870		D	above	16	136,00	8,00	113,00
N221/10c below	left	1,99	2,39	470		D	below	20	136,00	8,00	-113,00
N221/10c below	left	1,74	2,08	560		D	below	20	136,00	8,00	-113,00
N221/10c below	left	1,35	1,61	730		D	below	20	136,00	8,00	-113,00
N221/10c below	left	1,12	1,34	870		D	below	20	136,00	8,00	-113,00
NH/1b	right	0,91	1,09	1000	90,00	D	coaxial	5	110,00	0,00	0,00
NH/1c	right	0,91	1,09	1000		D	coaxial	5	52,00	0,00	0,00
NH/4b	left	1,16	1,40	430	90,00	K<60 min	above	6	142,00	0,00	80,00
NH/4b	left	1,16	1,40	430	90,00	K<60 min	right	7	142,00	80,00	0,00
NH/4b	left	1,16	1,40	430	90,00	K<60 min	below	8	142,00	0,00	-80,00
NH/4c	left	1,16	1,40	430		K<60 min	above	6	99,00	0,00	80,00
NH/4c	left	1,16	1,40	430		K<60 min	right	7	99,00	80,00	0,00
NH/4c	left	1,16	1,40	430		K<60 min	below	8	99,00	0,00	-80,00
NL/1b on N221/10 above	right	0,91	1,09	600	90,00	D	coaxial	17	264,00	0,00	0,00
NL/1b on N221/10 below	right	0,91	1,09	600	90,00	D	coaxial	21	264,00	0,00	0,00
NL/1c on N221/10 above	right	0,91	1,09	600		D	coaxial	17	206,00	0,00	0,00
NL/1c on N221/10 below	right	0,91	1,09	600		D	coaxial	21	206,00	0,00	0,00
NL/4b on N221/10 above	left	1,16	1,40	430	90,00	K<60 min	right	18	296,00	80,00	0,00
NL/4b on N221/10 above	left	1,16	1,40	430	90,00	K<60 min	below	19	296,00	0,00	-80,00
NL/4b on N221/10 below	left	1,16	1,40	430	90,00	K<60 min	above	23	296,00	0,00	80,00
NL/4b on N221/10 below	left	1,16	1,40	430	90,00	K<60 min	right	22	296,00	80,00	0,00
NL/4c on N221/10 above	left	1,16	1,40	430		K<60 min	right	18	253,00	80,00	0,00
NL/4c on N221/10 above	left	1,16	1,40	430		K<60 min	below	19	253,00	0,00	-80,00
NL/4c on N221/10 below	left	1,16	1,40	430		K<60 min	above	23	253,00	0,00	80,00
NL/4c on N221/10 below	left	1,16	1,40	430		K<60 min	right	22	253,00	80,00	0,00

Position: Flywheel

Vorg\_x [ mm ]: 0,00    Vorg\_y [ mm ]: 0,00    Vorg\_z [ mm ]: 0,00

Designation	Direct. of rotation	Speed factor f	Torque [ Nm ]	Flange diameter [ mm ]	Operating period	Installed position	Fig. <span style="border: 1px solid black; padding: 0 2px;">a</span>	NA_x [ mm ]	NA_y [ mm ]	NA_z [ mm ]
NMV221	left	0,98	2000	150,00	D	above	1	435,00	38,00	300,00

**Ecomat**

Power take-offs for gearbox:							<b>6 HP 602 (Standard) 5,6 – 0,83</b>			
Position: On the side of gearbox left of main output flange										
Vorg_x [ mm ]: 80,00		Vorg_y [ mm ]: -121,00		Vorg_z [ mm ]: 210,00		Gearbox flange diameter [ mm ]: 180,00				
Designation	Direct. of rotation	Speed factor f	Torque [ Nm ]	Flange diameter [ mm ]	Operating period	Installed position	Fig. <span style="border: 1px solid red; padding: 0 2px;">a</span>	NA_x [ mm ]	NA_y [ mm ]	NA_z [ mm ]
D01b left	right	0,97	950	100,00	D	left	3	229,00	-37,00	63,00
D02c left	right	0,97	950		D	left	3	214,00	-37,00	63,00
D05.3b left	left	1,44	600	100,00	D	300°	4	325,00	76,00	63,00
D05.4b left	left	2,12	400	100,00	D	300°	4	325,00	76,00	63,00

Position: On the side of gearbox right of main output flange										
Vorg_x [ mm ]: 80,00		Vorg_y [ mm ]: 121,00		Vorg_z [ mm ]: 210,00		Gearbox flange diameter [ mm ]: 180,00				
Designation	Direct. of rotation	Speed factor f	Torque [ Nm ]	Flange diameter [ mm ]	Operating period	Installed position	Fig. <span style="border: 1px solid red; padding: 0 2px;">a</span>	NA_x [ mm ]	NA_y [ mm ]	NA_z [ mm ]
D01b right	left	0,97	950	100,00	D	right	3	229,00	37,00	63,00
D02c right	left	0,97	950		D	right	3	214,00	37,00	63,00
D05.3b right	right	1,44	600	100,00	D	120°	4	325,00	150,00	63,00
D05.3b right	right	1,44	600	100,00	D	300°	4	325,00	-76,00	63,00
D05.4b right	right	2,12	400	100,00	D	120°	4	325,00	150,00	63,00
D05.4b right	right	2,12	400	100,00	D	300°	4	325,00	-76,00	63,00